

# Circuit diagrams

## 2 Speed, 1 Winding; 2 Speed, 2 Winding

### A9 – A750

00.00 Inches  
00.00 [Millimeters]

**2 Speed, 1 winding** – constant or variable torque, selective control  
A9 – A750 shown with control circuit transformer, HOA, STOP-FAST-SLOW

3

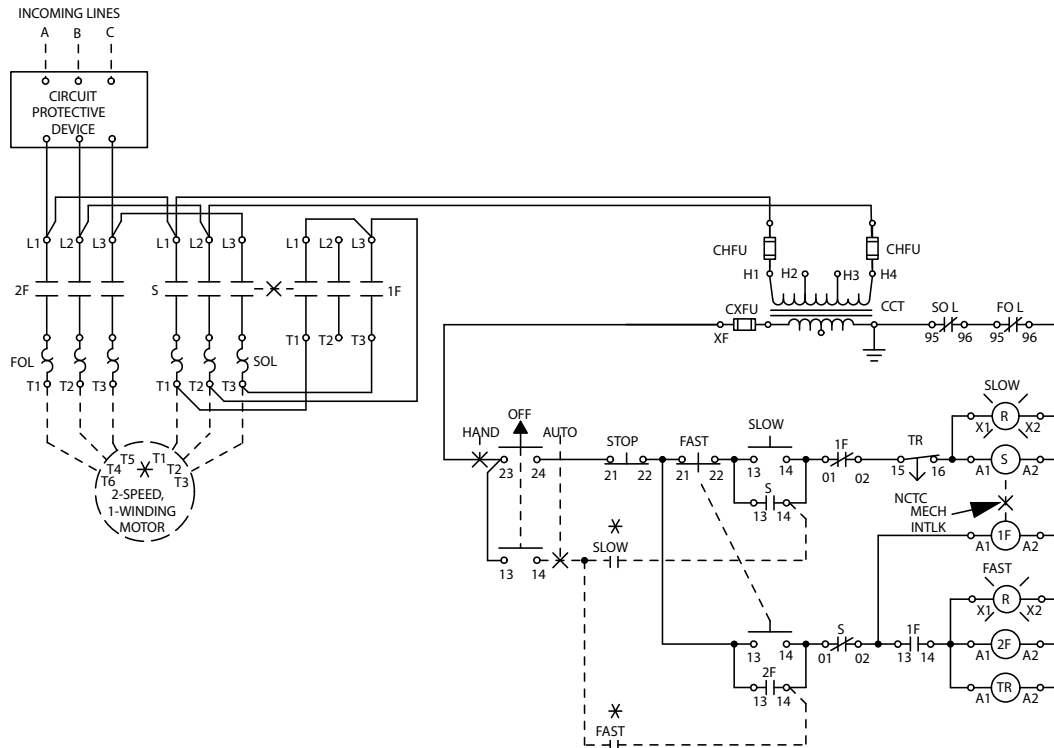

**2 Speed, 2 winding**  
A9 – A750 shown with control circuit transformer, FAST-SLOW-OFF-AUTO

