



MNS-MCC

Low Voltage Motor Control Center

Installation Manual

Table of Contents

Important User Information	3
1. General Information and System Description	5
1.1. System Overview	5
1.2. Component Names	5
1.3. Technical Data Table	6
1.4. MNS-MCC Standard Configuration	7
1.5. Nameplates and Labels	8
1.6. Mechanical Design	9
1.7. Bus Bar Compartments	10
1.8. Equipment Compartment	11
1.9. Wireways	13
2. Packaging and Handling	15
2.1. General	15
2.2. Receiving	15
2.3. Unloading and Moving MCC Components	15
3. Installing	19
3.1. Installation Location Requirements	19
3.2. Installation Guidelines	20
3.3. Section Installation Sequence	20
3.4. Installing and Connecting Shipping Splits	20
3.5. Splicing Horizontal Bus Bars	21
3.6. Changing Cubical Height	23
3.7. Fastening Sections to a Floor, Base Frame and Wall	26
3.8. Installation on False Floors	26
3.9. Cable Connections and Wiring	26
3.10. Other Installation Information	29
3.11. Commissioning	29
4. Operation	31
4.1. Fixed and Plug-in Units	31
4.2. Withdrawable Units	31
5. Maintenance	34
5.1. General Safety Instructions	34
5.2. Lock out/Tag out	34
5.3. Tighten Unit Control and Power Terminals	34
5.4. Remove/Insert Withdrawable Units	34
5.5. Troubleshoot Withdrawable Unit Interlock	36
5.6. Inspect Units	37
5.7. Exterior Metal Damage Repair	37
5.8. Maintenance Schedule	37
5.9. Arc Flash Protection	37
5.10. Additional Resources	38
6. Torque Tables	39
6.1. Product Assembly Torque Application	39

Important User Information

ABB shall not assume any liability for any of the following:

- Negligent handling of the MNS-MCC (Motor Control Center) system
- Insufficient maintenance or non-compliance with the recommendations presented in this manual or other documents related to the MCC and its components
- Inappropriate repairs or modifications to the equipment
- Operation, installation or maintenance of the equipment by personnel who lack appropriate training and/or authorization
- Failure to follow appropriate safety procedures or use the proper personal protective equipment, including arc flash, insulating, shielding materials, and use of insulated tools and test equipment per the National Electrical Safety Code (ANSI C2) and Electrical Equipment Maintenance (NFPA 70E).

The examples and diagrams in this manual are included exclusively for illustrative purposes. Because many variables and requirements are associated with each particular installation, ABB, Inc. cannot assume responsibility or liability for actual use based on the examples and diagrams. Reproduction of the contents of this manual, in whole or in part, without written permission of ABB, Inc., is prohibited.

SAFETY NOTICES

READ THIS MANUAL CAREFULLY BEFORE ATTEMPTING TO INSTALL, OPERATE OR MAINTAIN THIS EQUIPMENT
Refer to the NEMA ICS 2.3 “Instruction for the Handling, Installation, Operation, and Maintenance of Motor Control Centers” for important safety information. No information in this manual supersedes the NEMA standards and codes related to MCC installation, operation and maintenance.

Keep this manual available for the installation, operation and maintenance of this equipment. After installing the equipment, file these instructions with other instruction books, drawings and descriptive data for this equipment. Using these instructions will facilitate proper equipment maintenance and prolong its useful life.

Install the MCC within the design limitations described in this manual. This equipment is designed to operate within the current and voltage limitations on the main nameplate. Do not use or install this equipment in applications or systems using current and/or voltages that exceed its limits.

Follow your company’s safety procedures.

Important User Information

Do not remove covers, open doors or work on equipment unless power has been turned off and all circuits de-energized. All components should be electrically disconnected by means of a visible break, securely grounded and locked out, and tagged in accordance with precautions stated in ANSI Standard Z244.1 "Control of Hazardous Energy – Lockout/Tagout and Alternative Methods" and ISO Standards.

Personnel performing installation, operation or maintenance work on the equipment should wear the appropriate personal protective equipment.

Personnel installing, operating or maintaining this equipment must have thorough knowledge of all applicable local, regional, industry, governmental, ISO and OSHA safety procedures. They must also follow commonly accepted safe working practices based on the potential hazards involved. Personnel working in or around this equipment must use common sense and good judgment regarding the potential hazards to themselves and other personnel in the area.

These instructions are intended for use by fully qualified personnel and are not a substitute for adequate training, experience and supervision. This manual is not intended to be a substitute for adequate training and experience in the safety procedures related to this device. If you require clarification or additional information, contact your ABB representative. Please reference the Project Number shown on the main nameplate (See Lineup Nameplate section of this manual).

Warning

Detailed descriptions of standard repair procedures, safety principles and service operations are not included. It is important to note this document contains some warnings and cautions against some specific service methods that could cause personal injury to service personnel, damage equipment, or render it unsafe. These warnings do not cover all conceivable ways in which service, whether or not recommended by ABB, might be performed, or the possible hazardous consequences of each conceivable way, nor could ABB investigate all such ways. Anyone using service procedures or tools, whether or not recommended by ABB, must satisfy himself or herself thoroughly that neither personal safety, nor equipment safety, will be jeopardized by the service method or tools selected. Should further information be required or specific problems arise that are not sufficiently covered, refer the matter to an ABB service representative.

The purchaser, installer or ultimate user is responsible for ensuring that warning signs are attached and all access doors and operating handles are securely locked when the gear is left unattended, even momentarily.

All information contained in this manual is based on the latest product information available at the time of printing. The right is reserved to make changes at any time without notice.

Safety notations alert personnel to possible death, injury or property damage situations. The following four safety notations and words are used in the manual to indicate the degree of hazard that may be encountered by the user.

 **DANGER**
"Danger" – Indicates an imminently hazardous situation which is not avoided and has a high probability of death or serious injury and substantial property damage.

 **WARNING**
"Warning" – Indicates a potential hazardous situation which is not avoided and has some probability of death or serious injury and substantial property damage.

 **CAUTION**
"Caution" – Indicates a potential hazardous situation which is not avoided and has a minor or moderate probability of death or serious injury and substantial property damage.

 **NOTICE**
"Notice" – Indicates a statement of company policy as it relates directly to the safety of personnel or protection of property.

1. General Information and System Description

1.1. System Overview

The MNS-MCC Motor Control Center (MCC) consists of one or more vertical metal cabinets referred to as “sections.” Each section contains one or more modular units - fixed, plug-in or withdrawable - that are employed to distribute power to discrete loads, such as motors and other loads

MNS-MCC is available in two (2) different versions: Standard and Compact. The major difference is the section height and the size of the horizontal wireways. The height of the Standard Version is 2300 mm (90.6 in), while the Compact Version is 2200 mm (86.6 in).

The standard MCC section width is 500 mm (19.7 in) in a front-mounted configuration only. The standard depth is 500 mm (19.7 in). Optional section widths are 600 mm (23.6 in), 700 mm (27.8 in), 800 mm (31.5 in), 900 mm (35.4 in), 1000 mm (39.4 in) and 1200 mm (47.2 in).

All MCC sections include top and bottom horizontal wireways. Sections that house withdrawable and plug-in units include vertical bussing and a vertical wireway on the right-hand side of the section.

Each unit may house one of a wide variety of power and logic devices. Units may be either door-closed withdrawable, plug-in or fixed-mounted types. Both the withdrawable and plug-in units incorporate input plugs that mate with ABB’s IP20 multi-function wall that features embedded vertical bussing.

Units feature hinged doors held closed by one or more quarter-turn latches. If the unit contains a circuit protective device, such as a molded-case circuit breaker, motor circuit protector or fused disconnect switch, a rotary operating handle on the outside of the unit door will allow operation of the disconnecting means from outside the unit. Fixed and plug-in units feature operating handles that may be padlocked with up to three padlocks. The operating handle is interlocked with the disconnecting means within the unit, preventing the unit door from being opened if the handle is in the ON position (may be defeated with the use of a tool), or prevent the door from being opened if the handle is padlocked in the OFF position. Withdrawable units feature a multi-position handle that controls the disconnecting means as well as a mechanical interlock, preventing the unit from being withdrawn from the MCC unless the operating handle is in the Move position and the disconnecting means is OFF.

A continuous horizontal bus, rated 800 to 4,000 amps, distributes incoming power to all MCC sections. The horizontal bus

is located, usually, in the top half of each section and may be additionally paralleled with another bus system installed in the bottom half of the section for higher current rating.

Each section may contain a vertical bus system rated 800A (standard) or up to 1600A (optional). The standard vertical bus is embedded in the multi-function wall (see the Multi-Function Wall), which separates the unit compartments at the front of the MCC from the horizontal bus at the rear of the MCC sections. The multi-function wall is provided with multiple tap points, which are IP20, and are used to provide power to plug-in and withdrawable units over the vertical height of the bus.

1.2. Component Names

This manual uses the following naming standards:

Bucket: See Unit.

Compartment: Sections are typically divided into three compartments: Equipment, Vertical Wireway and Bus.

Cubicle: The equipment compartment is sometimes divided into smaller areas to accommodate units of different height. One section may be divided into as many as 12 cubicles.

Drawer: See Unit.

Lineup: The arrangement of several vertical sections, joined side-by-side, to create a complete MCC with a continuous horizontal bus.

Module: See Unit.

Pan: See Unit.

Section (or vertical section): An enclosed vertical “cabinet” that supports and contains units, wireways and other internal constructions. Several sections are typically combined next to one to another to form a lineup.

Shipping Split: MCC lineups that include several vertical sections may be joined side-by-side at the factory into one or more “shipping splits.” This facilitates shipping, handling and installation. Up to three sections may be combined in a shipping split.

Unit: A fixed, plug-in or withdrawable electromechanical assembly that is mounted within a cubicle, e.g. a motor starter or feeder.

Vertical Section: See Section.

General Information and System Description

1.3. Technical Data Table

Standards		Type-tested Motor Control Center assemblies (TTA)*	UL 845, CSA C22.2 No. 254-05, NOM NMXJ853, UL 50, NEMA/ICS 1B, NFPA 70, 70E, IEEE 1584
Test certificates		The MNS-MCC is designed, tested, and constructed in accordance with the following industry standards and guidelines:	ANSI C84.1 (Voltage Tolerances for North America), Seismic Qualification to IBC-2006 and CBC-2007, AC156, "Shake-Table Testing for Nonstructural Components and Systems," and ASCE/SEI 7-05, "Minimum Design Loads for Buildings and Other Structures"
Electrical Data	Rated voltages	Rated insulation voltage U_i	1000 V 3~
		Rated operating voltage U_e	208, 240, 480 or 600 VAC
		System	3 phase-3 wire, 3 phase-4 wire
		Rated impulse withstand voltage	8 kV
		Rated frequency	up to 60 Hz
	Rated current	Main Bus bars	Rated currents up to 4000 A
			Rated peak withstand current 149.5 kA
	Distribution bars		Rated short-time withstand cr. up to 100 kA@480V or 65KA@600V
			Rated current 800A or 1600 A
			Rated peak withstand current 149.5 kA
			Rated short-time withstand cr. up to 100 kA@1600 A Bussing
Mechanical Charact.	Dimensions	Recommended height: mm(in)	2300(90.55) or 2200(86.6)
		Recommended width: mm(in)	500(19.7), 600(23.6), 700(27.6), 800(31.5), 900(35.5), 1000(39.4), 1200(47.2)
		Depth: mm(in)	500(19.7)
		Basic Unit (grid) size	E = 25 mm (App. 1 In)
	Surface protection	Frame	Alu-zinc coated
		Internal subdivision	Alu-zinc-coated
		Transverse section	Galvanized
		Enclosure	Paint finish ANSI 61
	Enclosure Type		NEMA 1A
	Plastic components	Halogen-free, self-extinguishing, flame retardant, CFC-free	
	Internal subdivision	Device compartment - device compartment	
		Bus bar compartment - cable compartment	
		Bus bar compartment - device compartment	
		Device compartment - cable compartment	
		Compartment bottom plates	
Extras	Paint finish	Enclosure	Special colors (standard ANSI 61)
	Bus bar system	Bus bars	Insulated

*Definition TTA: Switchgear assembly corresponding, to a large degree, with the original type or system of switchgear assembly type-tested in accordance with these standards.

1.4. MNS-MCC Standard Configuration

Structure

The MCC assembly consists of one or more metal enclosed vertical sections. Each vertical section has an internal framework for mounting one or more units, and a bus compartment in the rear of the section.

A continuous horizontal ground bus is located at the bottom of all section.

End sections are designed to allow for the addition of future sections.

The MCC may accept cable entry from the top, bottom or both.

Lifting angles are provided to allow lifting by crane. See “Crane Handling.”

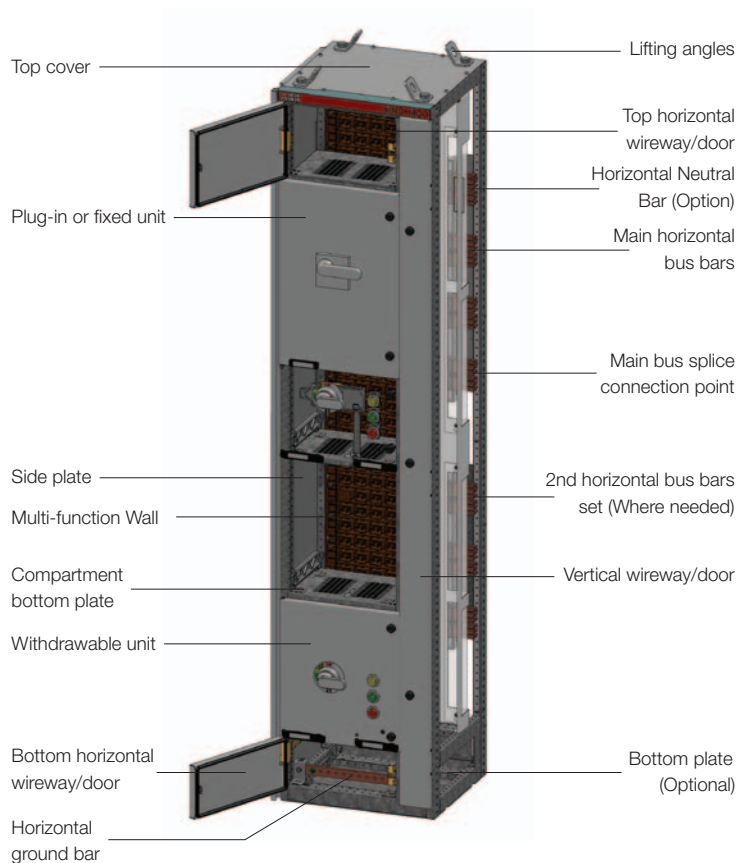

FIGURE 1. MCC Standard Configuration

MCC Dimensions

There are two versions of the MCC:

- MNS-MCC Standard version measures 2300 mm (90.5 in) height
- MNS-MCC Compact version measures 2200 mm (86.6 in)

There is an additional 50 mm (1.97 in) added to the total height by the lifting angles.

The section depth is 500 mm (19.7 in).

The standard section width is 500 mm (19.7 in). Wider sections up to 1200 mm (47.2 in) are available.

General Information and System Description

1.5. Nameplates and Labels

The MCC is provided with several nameplates and labels that display data related to the equipment electrical ratings and the specific application or installation.

MCC Main Nameplate

The MCC sections are organized side-by-side in a lineup that has a stainless steel master nameplate. This nameplate is usually located at the top horizontal wireway door on vertical section number 1. This nameplate will be in UL, CSA or NOM format, depending on the country. Fig. 2 shows a typical nameplate.

Vertical Section Label

Each section has a label located on the vertical wireway door, or on the unit door for sections without a wireway, that displays the approval agency marking, such as UL, CSA or NOM. Fig. 3 shows a typical label.

Unit Nameplate and Label

Each unit may have up to two nameplates located on the door left and right pull handles. These nameplates may include customer-specific information for the specific unit load. There will also be a label inside the door of each unit with technical information about the unit and indication of the unit's location within the lineup.

UL/CSA/NOM Marking

Vertical sections and units are labeled independently. You might have both labeled and non-labeled sections and/or units in the same lineup. Sections or units that are UL Listed or CSA Certified will be so marked.

ABB
Motor Control Center / Centre de commande de moteur
CSA STANDARD / STANDARD CSA C22.2 No. 254-05

Supply / Alimentation (Vac)	<input type="text"/>	Type / Modèle	<input type="text"/>
Incoming / Entrée (Type-Amp)	<input type="text"/>	MCC No. / No. de CCM	<input type="text"/>
Wires / Fils	<input type="text"/>	Frequency / Fréquence (Hz)	<input type="text"/>
Phases No. / No. Phases	<input type="text"/>	Construction type / Type de construction	<input type="text"/>
Horizontal / Horizontales (A)	<input type="text"/>	Control Voltage / Tension de contrôle	<input type="text"/>
Ground / M.A.L.T (A)	<input type="text"/>	Manufacturing year / Année de fabrication	<input type="text"/>
Neutral / Neutre (A)	<input type="text"/>	Project No. / No. de projet	<input type="text"/>
Bus system Short-circuit Current Rating / Courant nominal des barres sous court-circuit	<input type="text"/>	A rms sym.	

CSA NOM
MC 163516

MADE IN MEXICO / FABRIQUÉ AU MEXIQUE

FIGURE 2. MCC Main nameplate

ABB
Motor Control Center / Centre de commande de moteur
CSA STANDARD / STANDARD CSA C22.2 No. 254-05

Type / Modèle	<input type="text"/>	Construction type / Type de const.	<input type="text"/>
Supply / Alimentation	<input type="text"/>	MCC No. / No. de CCM	<input type="text"/>
Vertical / Verticale (A)	<input type="text"/>	Project No. / No. de projet	<input type="text"/>
Ground / M.A.L.T (A)	<input type="text"/>	Section No. / No. de Section	<input type="text"/>
Neutral / Neutre (A)	<input type="text"/>	Mfg. year / Année de fabrication	<input type="text"/>
Freq. / Fréquence (Hz)	<input type="text"/>	Bus system SCC Rating	<input type="text"/>
Control Voltage / Tension de contrôle	<input type="text"/>	Courant des barres sous court-circuit A rms sym.	

Do not install on circuit with available short-circuit current greater than the lowest short-circuit rating of any installed units / Ne pas installer sur un système ayant une capacité de court-circuit plus grande que la capacité minimum des autres unités installées.

CSA NOM
MC 163516

MADE IN MEXICO / FABRIQUÉ AU MEXIQUE

FIGURE 3. Vertical Section Label

ABB

Order No.	<input type="text"/>	Nominal Voltage	<input type="text"/> V	MNS-MCC	
Type	<input type="text"/>	Nominal Current	<input type="text"/> A	Circuit diagram	<input type="text"/>
Phases / Wires	<input type="text"/>	Nominal power	<input type="text"/> HP	Frequency	<input type="text"/> Hz
		Control voltage	<input type="text"/> V	Fusing	<input type="text"/> A
Unit location	<input type="text"/>	Use	<input type="text"/> AWG	75 °C Wire	<input type="text"/>
Tightening torque for field-installed power conductors	<input type="text"/>			N-m	<input type="text"/>

2TDA080012P0002

FIGURE 4. Unit Nameplate and Label

1.6. Mechanical Design

The basic mechanical design includes:

Frame: Folded sheet metal C-profile used to create the framework of the sections.

Enclosure: The metal sheets that are attached to the frame, creating the complete section.

Internal constructions: The cubicles, units, wireways and other components inside the MCC.

Sections are constructed from galvanized or powder-coated steel.

Section Arrangement

MCC vertical sections are composed of the following three main compartments:

Bus bar compartment: The compartment where the main bus bar system is installed.

Equipment compartment: Composed of one or more cubicles that house the installed units (e.g. feeders, starters, etc.), the main functional elements of the MCC.

The other two compartments provide power to and from the units in the equipment compartment. See the Vertical Section Numbering section of this manual for details on the coding system used to identify the placement of units in this compartment.

Cable compartment (or wireway): The location of most power and control wiring connected to units.

The bus bars compartment is separated from the equipment compartment by the multi-function wall and/or other additional barriers. It is separated from the vertical wireway by metal sheets and a transparent plastic shield that covers the main bus splice links.

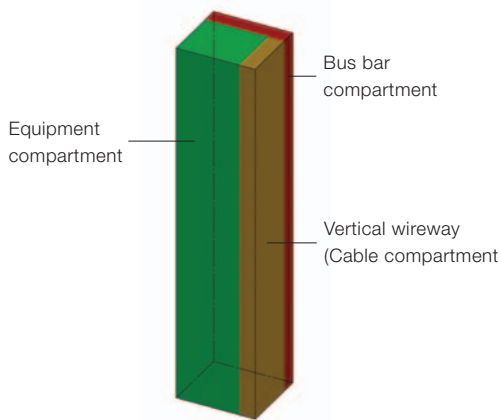

FIGURE 5. MCC Standard Compartments

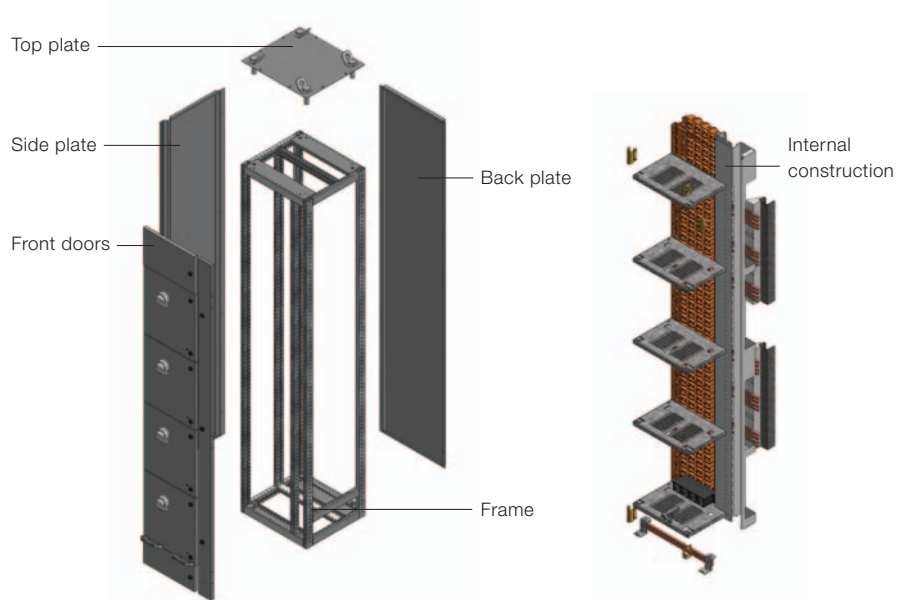

FIGURE 6. Frame, Enclosure and Inside Constructions

General Information and System Description

1.7. Bus Bar Compartments

The main horizontal bus bar is installed in the bus bar compartment located at the rear of the MCC. The main horizontal bus may be supplied in various configurations depending on the current rating.

This main bus runs the width of each section. The bus in each section is designed to allow splicing with the bus of the adjacent sections to create a continuous horizontal bus the length of the lineup. The splice links are located on the right-hand side of each section and are slid to the right to bridge to the bus in the adjacent section.

The horizontal bus is isolated from the front accessible areas but is not isolated phase-to-phase. An insulated bus bar is available as an option.

Bus Phases

The horizontal bus bar runs A, B and C phases from top to bottom of each vertical section in one or two levels.

Single-bus bar systems are installed at the upper level. Double-bus bar systems are installed at the upper and lower level.

Depending on the current ratings, 2 or 4 (for one set) or 8 (for two sets) of bars per phase are installed.

Only MCC sections with the same horizontal bus configuration may be coupled (or spliced) together.

Bus bars systems may be configured in three or four poles. See the Horizontal Neutral Bus section.

The horizontal bus bars are divided into lengths in accordance with the length of the MCC section. Sections in the same shipping split will be connected at the factory. The shipping splits must be connected together during installation using the bus splice links provided on the right-hand side of each split. The splice link bolts must be tightened to the specified torque. See the Torque Table provided in this manual.

The bus splice links are accessible through a barrier in the vertical wireway via a removable transparent window.

NOTE: It is necessary to routinely inspect splice link connections. Check the torque indication via the transparent shield inside the vertical wireway of each section.

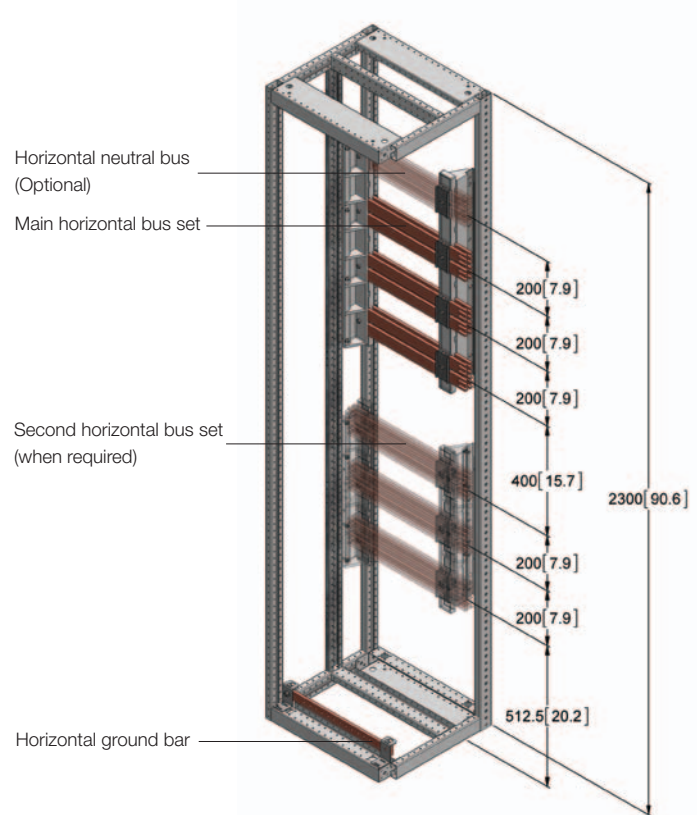

FIGURE 7. Horizontal Bus Bars

Main bus amperages include: 800A, 1200A, 1600A, 2000A and 2500A (non-ventilated), and 2000A, 3200A and 4000A (ventilated) configurations. Bus bracing is available up to a maximum of 100kA @ 480V and 65kA @ 600V.

Horizontal bus is available in tin-plated copper or optional silver-plated copper.

Horizontal Neutral

A neutral bus is available as an option. It will be located above A Phase at the top of the MCC, rated 2,000A maximum.

Horizontal Ground Bar

A continuous, sectionalized, bare-copper ground bus is provided at the bottom front of all sections, rated 400A.

The ground bus is provided with a series of regular 10 mm (0.39 in) holes for attaching ground lugs and other conductors.

Ground the MCC ground bus using equipment grounding conductors sized according to NEC 250-95, or by bonding to the raceway enclosing the main supply conductors according to NEC 250-92(B).

Vertical Distribution Bus Bar

The MCC standard vertical bus bars are 800A and are embedded inside the multi-function wall. The bus bars run A, B and C phase from left to right. These bus bars may feed the plug-in and withdrawable units. See Multi-Function Wall.

The vertical bus can be reinforced with additional buses installed on the rear of the multi-function wall, increasing the current rating from 800A to 1,600A.

They are available in silver-plated copper as standard.

Optional Bus Bars

- Vertical Ground Bar: May be added inside the multi-function wall.
- Vertical Neutral Bar: May be supplied in the vertical wireway. This option is available only for MCCs with vertical wireways 200 mm (7.87 in) wide (for a minimum section width of 600 mm (23.6 in)). The vertical neutral bar will be provided with a series of holes for connecting neutral cables using compression lugs.

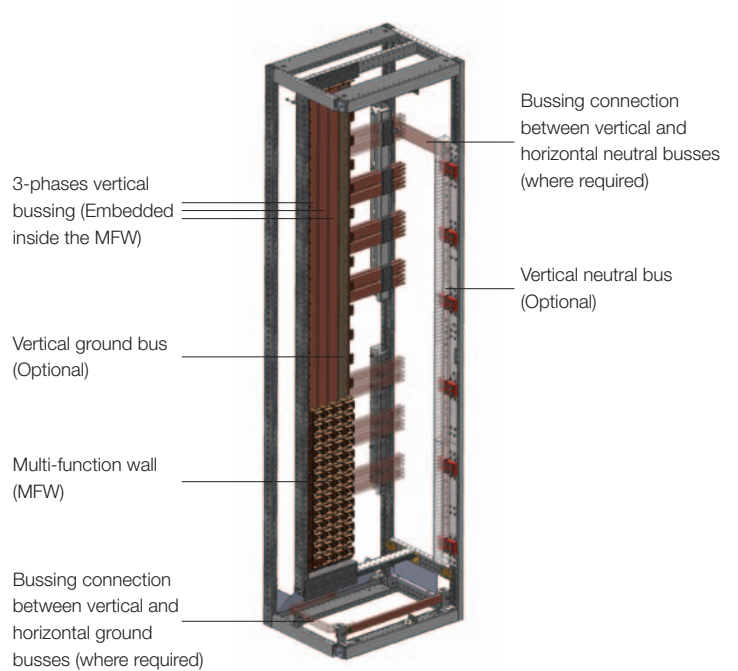

FIGURE 8. Vertical Distribution Bus Bar.

1.8. Equipment Compartment

The equipment compartment is composed of one or more cubicles housing units. These units include three types: fixed, plug-in and withdrawable. These units may be equipped with measuring, operating or indicating instruments. These instruments may be installed inside the units or, usually, on the front of the unit door.

Section and Unit Numbering

Each MCC section is sequentially numbered when the general arrangement drawings are prepared. The left-most section is usually 1, the next section to the right is 2, etc. This numbering scheme ensures the correct sequencing of vertical sections during installation.

Within each section, the equipment compartment is divided vertically into 72E. E is the Elementary grid or units. Each E height increment is equal to 25 mm (1 in). For example, a unit that is 300 mm (11.7 in) would be 12E.

The top location is designated as A. Each 2E units increment to the next letter of the alphabet. See Figure 9.

The next location designation after Z is AA. The bottom location is MM.

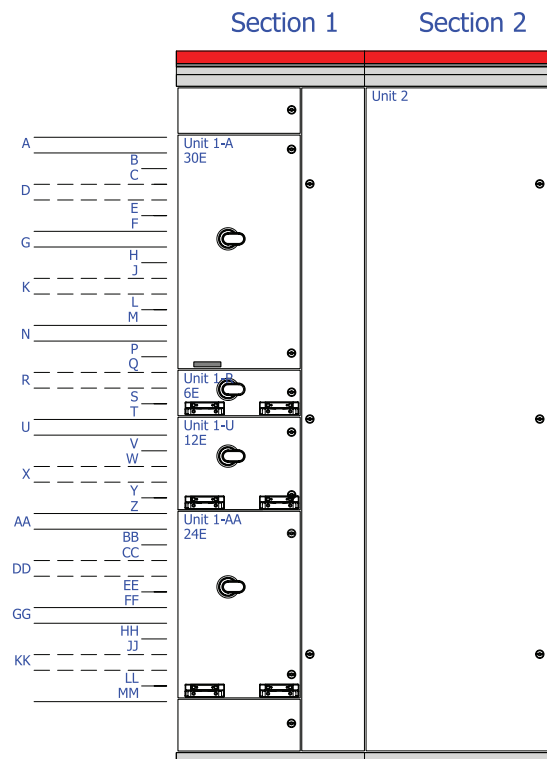

FIGURE 9. Unit Location Numbering

General Information and System Description

Each vertical section accommodates up to 12 X 6E (480V) or 6 X 12E (600V) total unit height.

The combination of the numeric section code (1, 2, 3 etc.) with the alphabetic 2E height code (A, B, C, etc.) uniquely describes each unit's location in the MCC. For example, the unit mounted in the top of the first section of a lineup would be coded 1-A. A unit mounted 750 mm (29.52 in) from the top of the first section would be 1-R.

Fixed Units

Fixed units are directly connected to the horizontal bus bars by bolted connections. These units do not fit in sections equipped with vertical bus (multi-function wall). Their connections could be made using either power cables or rigid bus bars.

Each unit is covered by a hinged door attached to the section frame and secured by one or more quarter-turn latches.

The unit may include an operating handle on the door that is interlocked to the unit door, preventing the door from being opened unless the circuit protective device is in the OFF position.

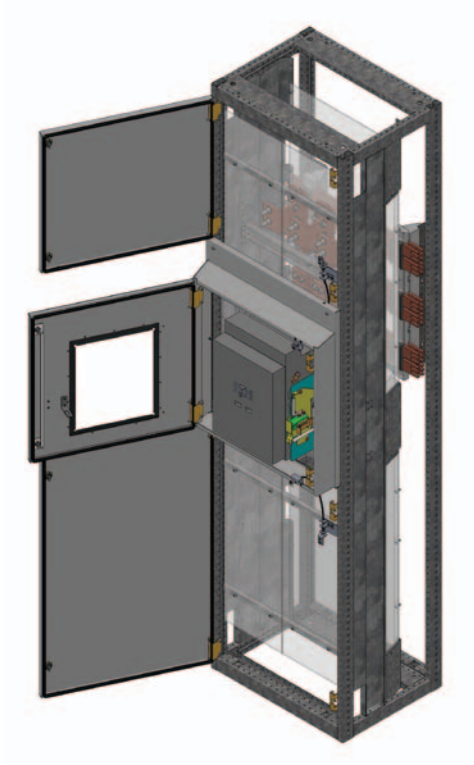

FIGURE 10. Fixed-Type Unit

On main incoming fixed units, a barrier is provided behind the unit door to prevent unintended contact with live parts.

MCCs equipped with main lugs only also are provided with a barrier behind the door to prevent unintended contact with live parts.

Plug-in Units

Incoming main circuit breakers and incoming main lug-only units may be plug-in type. These units tap and back feed the vertical bus within the multi-function wall.

These units are fastened directly to the section frame and are not readily removable. Plug-in units, including motor starter and feeder units, also tap the multi-function wall via input plugs on the back of these units. Plug-in units are fastened directly to the section frame and are not readily removable.

Similar to fixed units, plug-in units are covered by a hinged door attached directly to the section frame. Most of these units are equipped with circuit protective devices, such as circuit breakers or fused switches, and include operating handles interlocked to the front doors.

A barrier behind the door will be provided where needed to provide protection from live parts when the door is open.

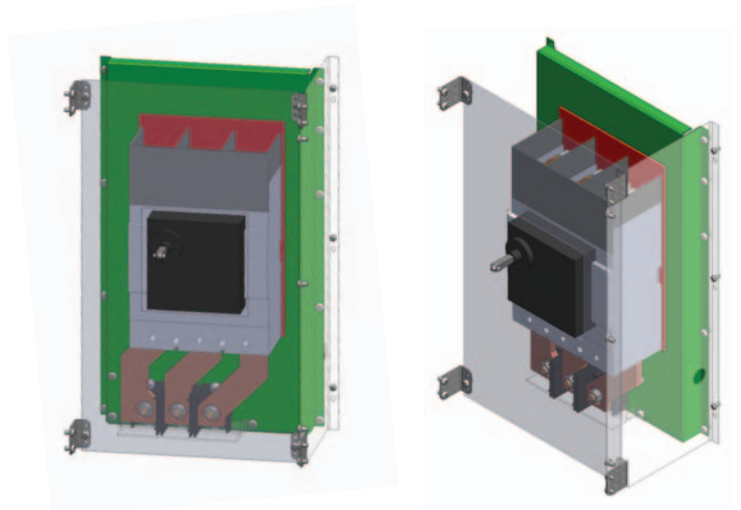

FIGURE 11. Plug-in Type

Withdrawable Units

These units are designed to allow quick insertion and removal of feeders, starters and other special control units without requiring the connection or disconnection of power or control wiring.

Withdrawable units have special self-connecting terminal blocks for incoming and outgoing power and control wiring, eliminating the need to manually disconnect control and especially power load terminations when removing a unit from the MCC.

Custom Control Unit

MCC sections may also include custom control units, whether empty (including a back plate only) or to be fitted / filled per customer requirement.

Multi-function Wall

Made from Ultramid® A3X2G5 (Nylon 66), the multi-function wall provides IP20 (Ingress Protection) protection against solid foreign objects 12.5 mm (0.5 in) and larger. It is an insulating, non-flammable and non-hygroscopic housing for the vertical bus. This design provides a degree of protection from unintended contact. It encapsulates the vertical bus and acts as an IP20 barrier between the front accessible areas of the MCC and the horizontal bus bar compartment behind. It isolates the vertical busses from the outside and, also, in between. The multi-function wall has no moving parts, such as moving shutters, and is maintenance-free.

Removable units are fed through the multi-function wall. Its design creates a chamber where each of the unit input plugs reaches the embedded vertical bus.

A reinforcement, non-insulated bussing system could be added to the back of the multi-function wall to increase its rating to 1600A (100kA at 600V).

1.9. Wireways

Vertical Wireway

The vertical wireway is provided in all sections that house removable units. The wireway is located on the right side of the section, extending the full height of the structure. It is used for top or bottom incoming power and control wires terminating into the individual units within the section.

The standard width of the vertical wireway is 100 mm (3.94 in). An optional 200 mm (7.87 in) wide wireway is available to provide additional working space. It increases the overall width of the section from 500 mm (19.7 in) to 600 mm (23.6 in).

The overall depth of a standard vertical wireway is 292 mm (11.5 in). The wireway includes connection points on the walls to support and secure wiring and cables.

The wireway has a full-height, hinged, 14-gauge steel door secured by three, quarter-turn latches. The vertical wireway door swings open 105° opposite of the unit doors for maximum accessibility (hinge on the right-hand side of the section frame).

To facilitate cable installation and improve accessibility in the wireway, the adjacent unit can be withdrawn from the cubical. If units are removed, ensure that they are properly marked, handled and stored. See Temporary Storage in this manual.

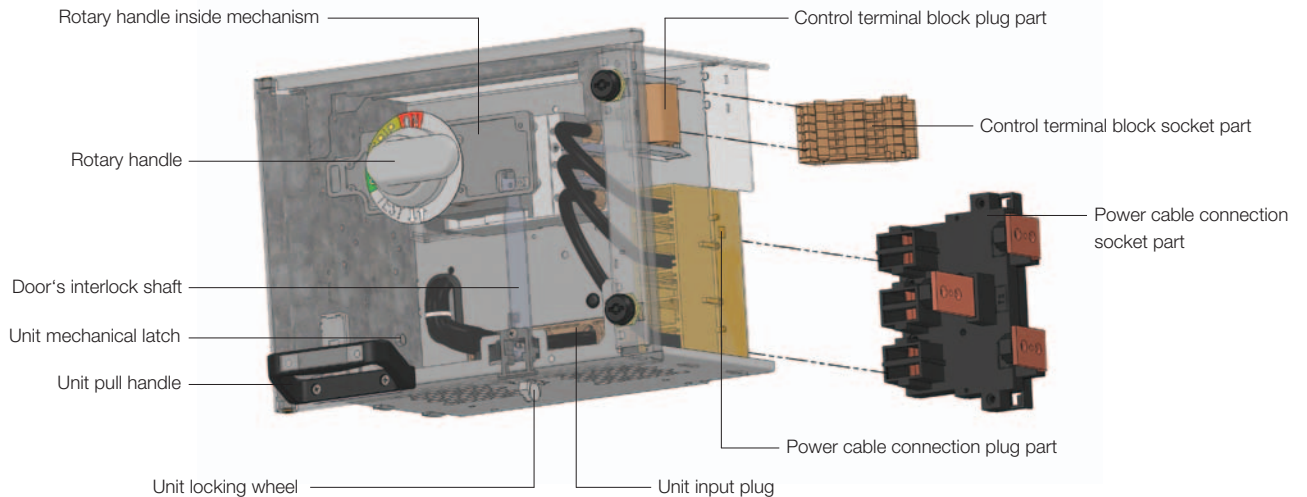

FIGURE 12. Withdrawable Type

General Information and System Description

Top Horizontal Wireway

- The MNS-MCC Standard version has a 277.5 mm (10.9 in) top horizontal wireway.
- The MNS-MCC Compact version has a 150 mm (5.9 in) top horizontal wireway.

The top horizontal wireway provides the space for interconnection wiring. It is covered by a steel, hinged door secured by a quarter-turn latch.

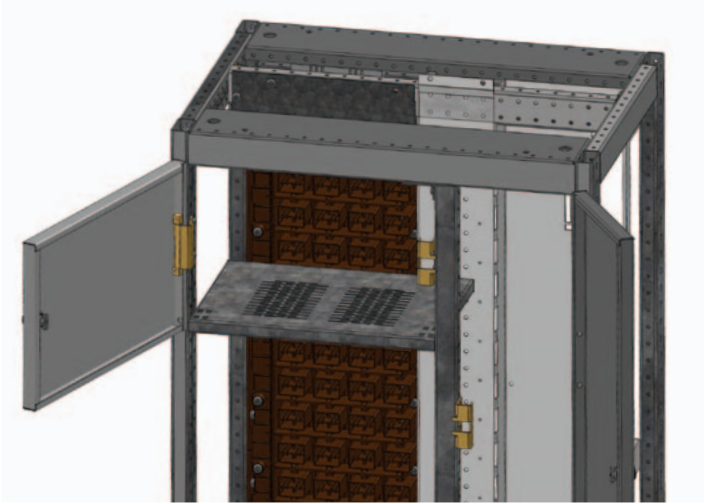

FIGURE 13. Top Horizontal Wireway

Bottom Horizontal Wireway

The bottom horizontal wireway is 175 mm (6.9 in) high in both the Standard and Compact versions. The wireway contains the horizontal ground bus, and is covered by a hinged door secured by a quarter-turn latch.

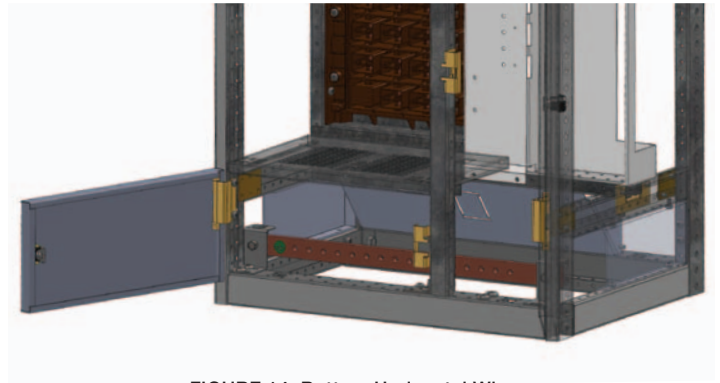

FIGURE 14. Bottom Horizontal Wireway

2. Packaging and Handling

2.1. General

Packaging will be done using ABB standard methods, unless the customer requires and requests special packaging.

MCC as standard are shipped in shipping splits of up to three sections. The width of shipping splits depends on the type of equipment installed and the width of the individual sections.



FIGURE 15. MCC General Arrangement - Shipping Splits

The maximum length for a motor control center shipping split is 60 inches (1500 mm). The skid length, for such Shipping split, will be 2032mm (80 In), the depth 813mm (32 In) and the height 150mm (6 In). For shorter shipping splits, two shorter skid types are available: 1702mm (67 In) or 1220mm (48 In) length.

Approximate values for weights per section in kilograms.

Model Section	App/ Weight Kg (lbs)
Incoming feeder1600A Section	350 (772)
Incoming feeder2500A Section	450 (992)
Incoming feeder3000A Section	600 (1322)
Withdrawable modules Section	290 (640)
MLO 1200 section	
MLO 2000 section	
MLO 3000 section	
MLO 4000 section	
VFD Full section	
Soft Starter Full section	
Empty section	

FIGURE 16. Table of Approximate Weights

Some heavy units or sensitive parts may be shipped separately.

2.2. Receiving

Before unloading, inspect each MCC component and/or its packaging for evidence of damage incurred during shipment. If there is any evidence the equipment has been damaged or mishandled, a qualified technician should perform a complete inspection of both the interior and exterior of the equipment. If there is damage from improper handling, file a claim for damages at once with the carrier and notify your ABB representative.

Retain all of the packing material until you are confident that you have all components and that they are suitable for installation.

Before shipment, each vertical section was inspected and marked with its assembly number and location within the lineup. See the Section and Unit numbering section of this manual. Check the equipment received against the packing list to ensure that all components were received. Notify your ABB representative and the carrier at once if there are any discrepancies between what was ordered and what was received.

If there will be a delay in installing the MCC, retain the necessary packing materials to safely store the MCC. See the Temporary Storage section of this manual.

2.3. Unloading and Moving MCC Components

Unload MCC sections or shipping splits either by crane or fork-lift and place them on a flat surface. When moving the sections or shipping splits, keep them vertical at all times.

MCC sections and shipping splits usually have a high center of gravity. To improve stability while moving them to the installation site, leave the sections or shipping splits secured to the shipping skid.



FIGURE 17. Shipping Pallets

Packaging and Handling

⚠ WARNING

The MCC includes very heavy components. To prevent serious injury or death, or equipment damage, use only material-handling equipment with sufficient capacity for the loads involved. Components should be unloaded and transported only by qualified operators and/or installers.

⚠ NOTICE

Never set the MCC sections on edge. To prevent deformation, sections should always rest flat on the floor or supporting structure.

Crane Handling

MCC sections are equipped with lifting angles to enable unloading and positioning using a crane. Do not fasten any lifting device directly to the vertical sections. Lift only using the lifting angles.

You can remove the lifting angles after the section is in position. If removed, replace the bolts.

The optimal lifting rope angle at the crane hook is 45°. The maximum rope loading is reduced for larger rope angles, as shown in Figure 18.

Use only slings and rigging hardware that comply with the applicable sections of ASME B30.20, ASME B30.26 and ASME B30.9.

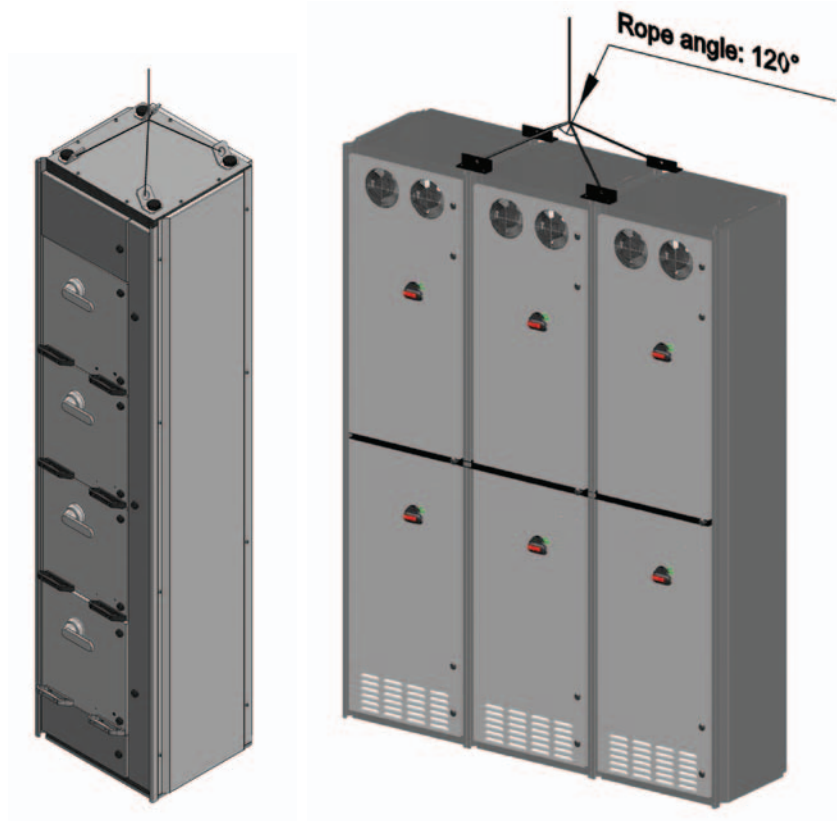

FIGURE 18. Crane Transport

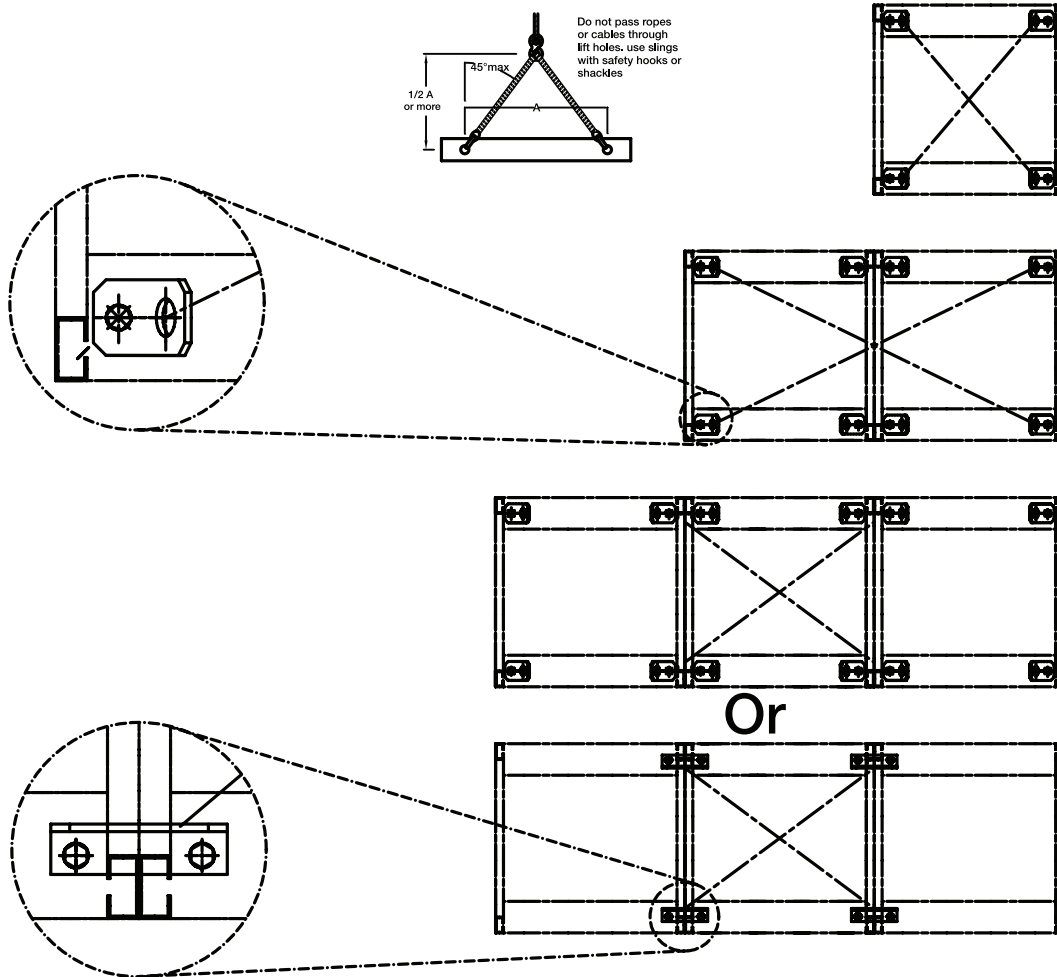

FIGURE 19. Arrangement of Lifting Angles

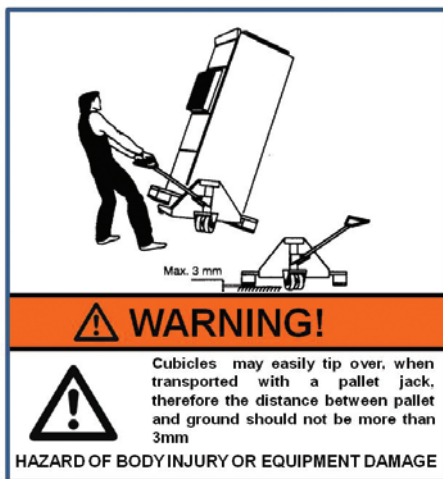

FIGURE 21. Transport with Pallet Jack Warning

Packaging and Handling

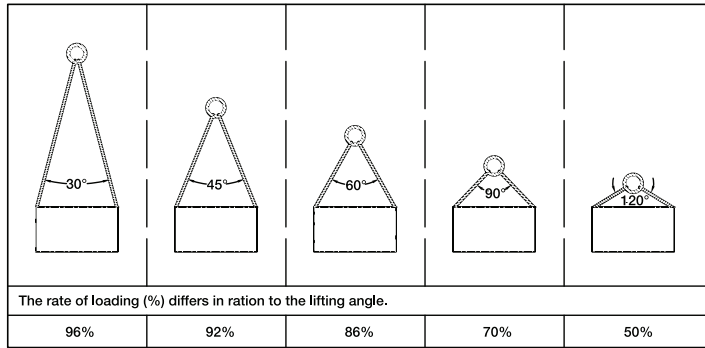

FIGURE 20. Guide Values for Permissible Rope Loading

Moving MCC Equipment

Move the equipment to the installation site using a forklift or pallet jack, or via rod/pipe rolling. MCC vertical sections are usually top- and front-heavy when units are installed, but top- and back-heavy when empty (withdrawable units removed). Be sure to balance your loads carefully when moving them, and use safety straps when handling with a forklift.

For added stability and safety, leave the sections attached to their shipping skids during transportation to the installation site.

At the installation site, you may tilt empty vertical sections back to the horizontal position if necessary to fit through doors or other low openings. When transporting sections horizontally, they must be supported over a wide area to avoid distortion or damage.

Temporary Storage

If the MCC won't be installed directly after arrival, it should be stored under the following conditions in order to avoid damage:

- Unpack the components immediately upon delivery so that they can be inspected for damage. See the Receiving section of this manual.
- Open section doors for several hours to acclimatize the equipment.
- Store the components indoors in a condensation-free environment.

Guide Values for Permissible Rope Loading

Rope Diameter mm	Permissible load of a four rope arrangement @ 120° lifting angle					
	Hemp rope		Perlon ropes		Steel ropes	
	Kg	lbs	Kg	lbs	Kg	lbs
8	-	-	-	-	890	1958
10	180	396	400	880	1440	3168
12	280	616	600	1320	2100	4620
14	350	770	820	1804	2900	6380
16	470	1034	1060	2332	-	-
18	580	1276	1340	2948	-	-
20	720	1584	1660	3652	-	-
24	1000	2200	2400	5280	-	-
30	1600	3520	-	-	-	-
36	2400	5280	-	-	-	-

*As per the following standards: DIN 83325 for Hemp, DIN 83330 for Perlon, DIN 15060 for Steel

- Store the equipment in an area where the ambient temperature remains above -25°C (-13°F) but will not exceed 65°C (149°F).
- Cover the sections with plastic sheeting to protect them from dripping water.
- Check once per week for condensation on the components. If condensation is detected, dry the equipment and move it to a different storage area.

TIP: You may be able to hang a 100 watt incandescent light bulb inside the MCC enclosure to act as a space heater and reduce condensation.

If your delivery includes spare units, store them following these instructions:

- Store in an area with temperatures above -10°C (14°F) but not exceeding 40°C (104°F) at 85% non-condensing humidity.
- Store the boxes top-side up.
- Do not stack units larger than 450 mm (18 in) on top of each other.

3. Installing

Before beginning the installation, ensure that you have all of the needed equipment (MCC sections, fastener hardware to connect sections and shipping split connection hardware) and make a final check that it is in good condition. If there is any evidence of damage to the equipment, contact your ABB representative to evaluate the condition of the equipment before proceeding with installation.

Carefully review all supplied project drawings to familiarize yourself with the layout and construction of the MCC.

Based on the footprint shown on the general arrangement drawings, make marks on the floor for all drilled holes necessary to fasten the MCC or base frame to the floor, and for cable conduits (if applicable). See the Fastening Sections to a Base Frame section in this manual.

3.1. Installation Location Requirements

The installation must meet the following qualifications:

- Indoor location protected from moisture and dramatic temperature changes; for longest equipment life, install the MCC in an enclosed room with temperature and humidity control, and filtered, forced-air ventilation
- Level the site, preferably including a base frame that is either embedded in the concrete floor or rests on a false floor on supports
- Proper openings in the floor, wall and ceiling for cables, conductors, pipes, bars and ventilation in accordance with the construction drawings provided
- Necessary conduits available to and from the site
- At least 80 mm (3.2 in) from the top of the highest section to the ceiling
- At least 80 mm (3.2 in) between the side and back of the sections and the surrounding walls
- At least 150 mm (5.9 in) between the last section to be installed (whether left or right) and the wall

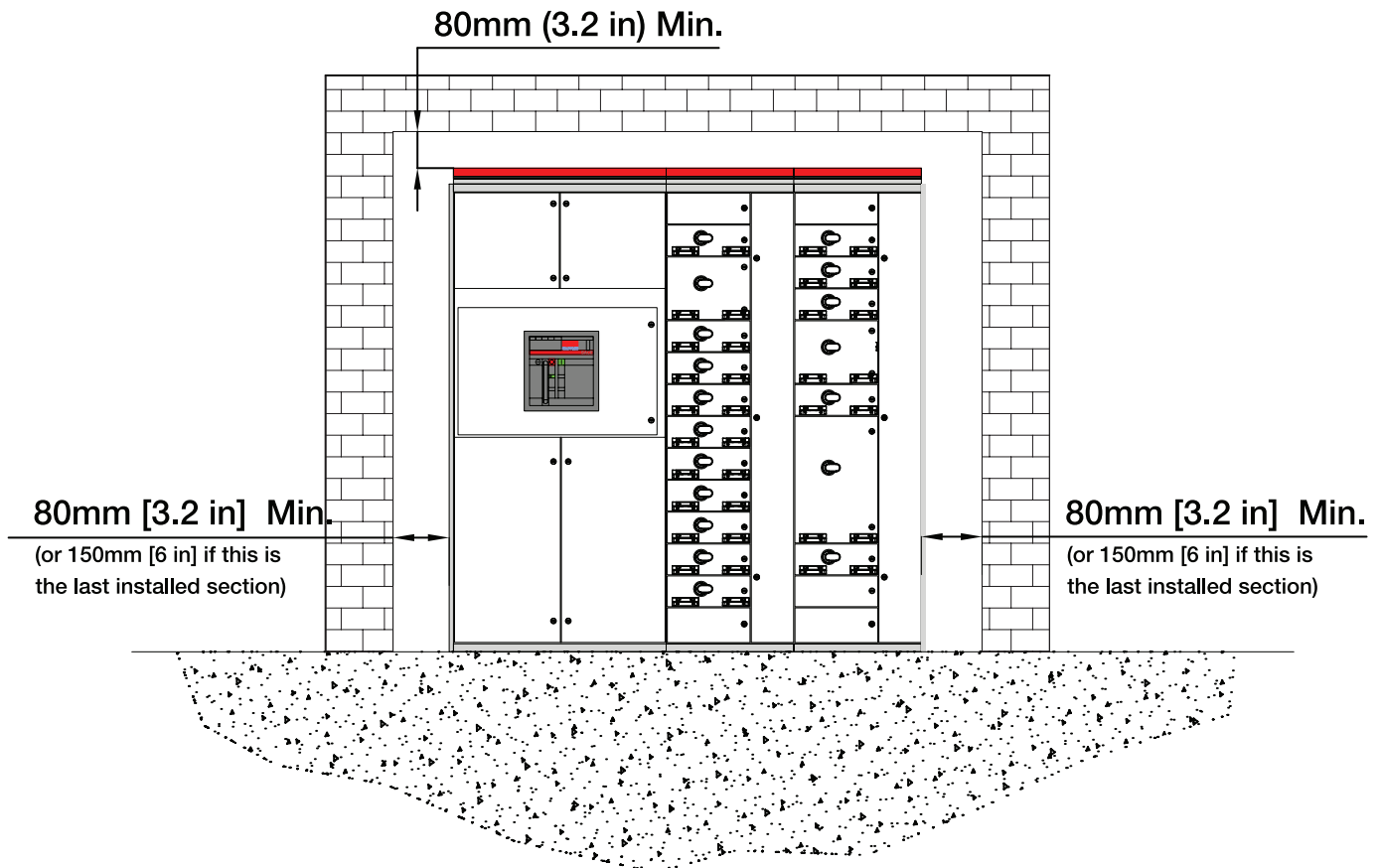

FIGURE 22. Wall Distance

Installing

- For MCCs with left-mounted doors, at least 152 mm (6 in) between the left wall and the left-end section so the doors can be opened more than 105°
- Convenient alignment with other equipment
- Accessibility for maintenance
- Ambient temperature above -10° C (14° F) but not exceeding 40°C (104°F) at 85% non-condensing humidity
- Sufficient space for future expansions, if required

The installation site also should meet these criteria:

- Supporting brackets, beams, enclosures and foundation frames assembled and painted or treated with other corrosion-resistant coating

To facilitate installation and maintenance, the site should also have:

- Adequate lighting
- Free access to the electrical equipment rooms

3.2. Installation Guidelines

⚠ WARNING

Follow all instructions related to the installation of the MCC to avoid potentially hazardous situations that could result in death or serious injury.

- Use appropriate personal protective equipment (PPE) and follow the safe electrical rules and work practices for electrical installations as described in standard NFPA 70E, and any other local safety rules and practices.
- The MCC must be installed, operated and serviced only by qualified personnel.
- If the installation is being done near operational equipment, it may be appropriate to erect temporary barriers between that equipment and the MCC.
- If you are adding sections to an existing MCC, turn off all power supplying this equipment before working on or inside it.
- Always use an appropriate voltage-sensing device to confirm that the power is off prior to installing or working with the MCC.
- Follow appropriate lockout/ tagout procedures.

3.3. Section Installation Sequence

Sections can be installed or added in any order, and new sections may be added between existing sections. If the sequential order designated during manufacturing is altered on site by adding sections to an existing lineup, the main bussing must match and the related drawings updated.

When adding, removing or rearranging sections, do not exceed the maximum amperage available on the horizontal bussing.

3.4. Installing and Connecting Shipping Splits

Position the shipping splits: Position the shipping splits in their final arrangement and location. Connecting the sections together before attaching them to the floor (or wall) will simplify splicing the horizontal bus.

If doors won't close easily, or panels are twisted or stressed, this may indicate that the site is not leveled. You may be able to shim the sections to level the site as necessary.

Connect the sections together: You can begin the installation at either the left or the right end of the lineup by connecting the frames of the sections together. The left side of each frame is fitted with threaded inserts. Sections are fitted on the right side with the necessary rivet nuts. Insert the bolts from the left side of one frame to the inserts in the adjoining section to the right.

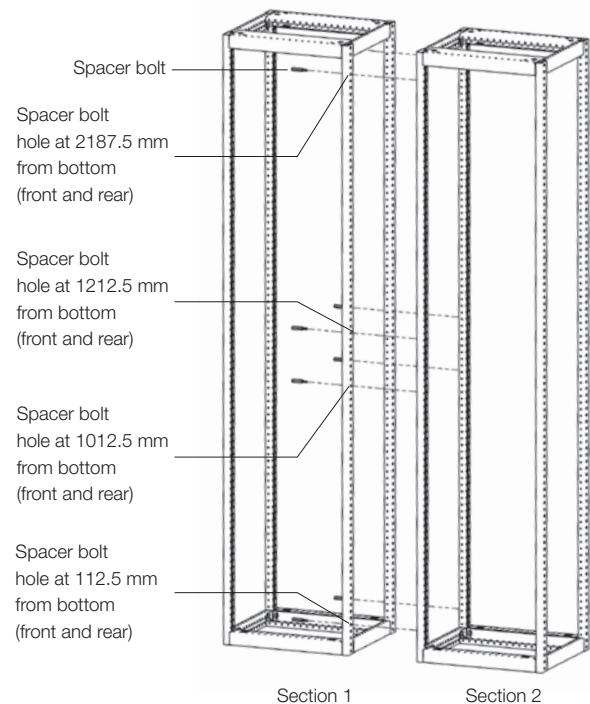

FIGURE 23. Frame Connection Using Spacer Bolts



FIGURE 24. Tighten the Spacer Bolts

Connect the sections using the provided hardware, consisting of eight (8) M6 bolts, typically provided in a clear plastic bag affixed to the front of the MCC shipping split.



FIGURE 25. Spacer Bolts Bag

Torque the bolts as per the Torque table at the end of this manual.

Attach the section to the floor/wall: After connecting the sections, you can attach the lineup to the floor and/or wall (Optional brackets exist to attach the top of the MCC to a wall). See the Fastening Sections to a Foundation or Wall Section of this manual.

Splice horizontal bus bar: See next section.

3.5. Splicing Horizontal Bus Bars

After installing and connecting the MCC shipping splits, connect the main horizontal bus splice links and tighten the hardware to the specified torque. Splice links are supplied from the factory, installed on the right-hand side of each shipping split.



FIGURE 26. Splice Links

Access the splice links by removing the transparent barrier at the rear of the vertical wireway.

Loosen the bolts holding the splice link(s) in place and slide the link(s) to the right to straddle the horizontal bus in the adjacent (right-hand) section. Carefully position the splice link so that it straddles the bus equally on both the left and right hand sections.



FIGURE 27. Slide the Link to the Adjacent Bus Bar

Tighten the four (4) M8 bolts using a 13mm socket wrench. Torque the bolts to 35Nm (25.7 lbs/ft). It is recommended to use a long ratchet extension that extends outside the front of the wireway, and a 13mm socket with an integral universal joint, to easily access and tighten all of the bolts.

Installing



FIGURE 28. Frame Connection Using Spacer Bolts

Mark the torque bolts.

Repeat this process for all of the horizontal bus splices, including the neutral bus if provided.

Replace the transparent barrier(s).

The horizontal ground bus in the lower wireway must be spliced between adjacent sections. Splice links are also provided on the right-hand side of each section and may be loosened and bridged to the adjacent section.

NOTE: The holes at the ends of all bus bars ensure adequate adjustment within the required tolerances. If the lineup has been installed properly, the bus bars in adjacent sections will line up. Never drill or modify bus bars if alignment is poor. Ensure that the adjacent sections are properly and completely connected together mechanically before connecting the horizontal bus splices.

Do not clean the contact surfaces on a new MCC. For connections to existing MCCs with heavy oxidation, you may need to clean the contact surfaces by sanding lightly with a fine grain aluminum oxide paper.

Refer to the Torque Table at the end of this manual for tightening torques for horizontal busses bolted connections that include: main, neutral and ground bus bars.

Additional connections to the central ground system and the MCC ground bus can be made at any point on the perforated ground bus. Ground cables should not be run in conduit and should take the most direct path to the site ground.

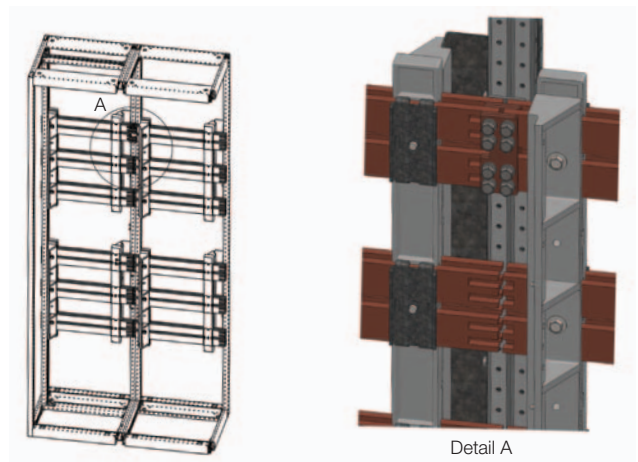

Main Bus Splice Links Overview

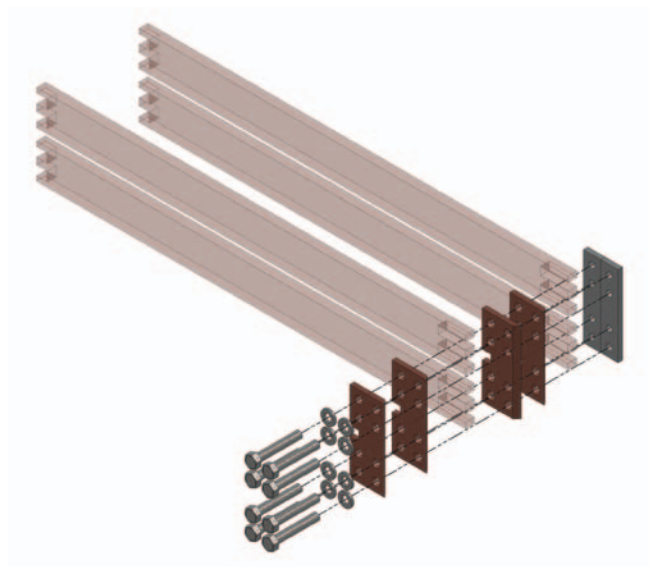

Splice Link Set Detailed View
FIGURE 29. Bus Bar Connections

3.6. Changing Cubical Height

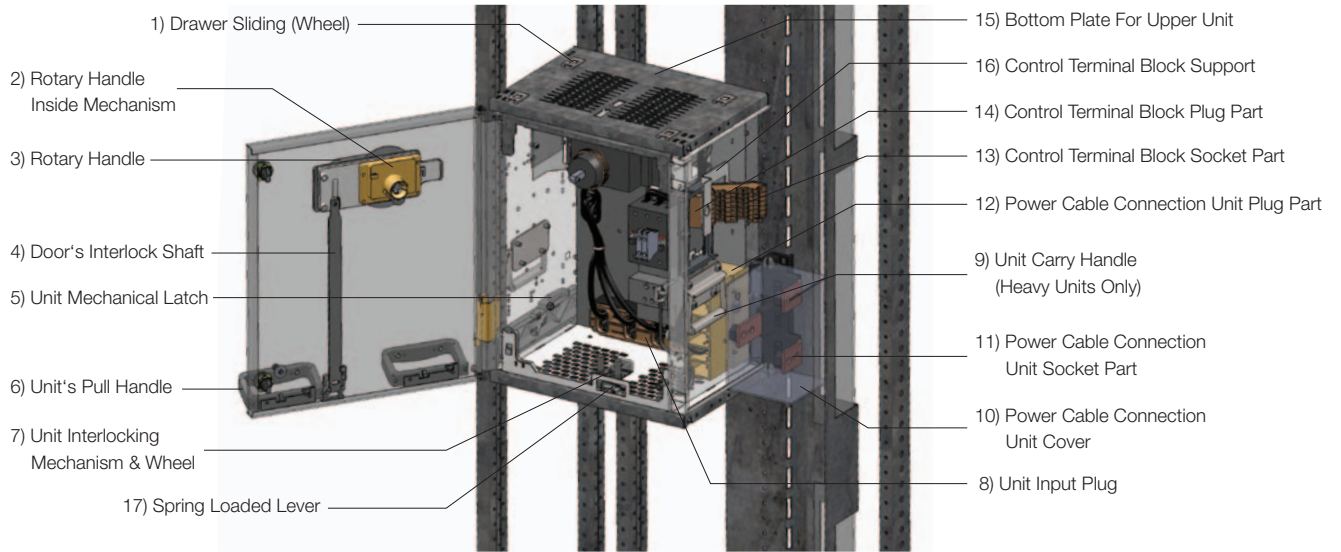

FIGURE 30. Withdrawable Units

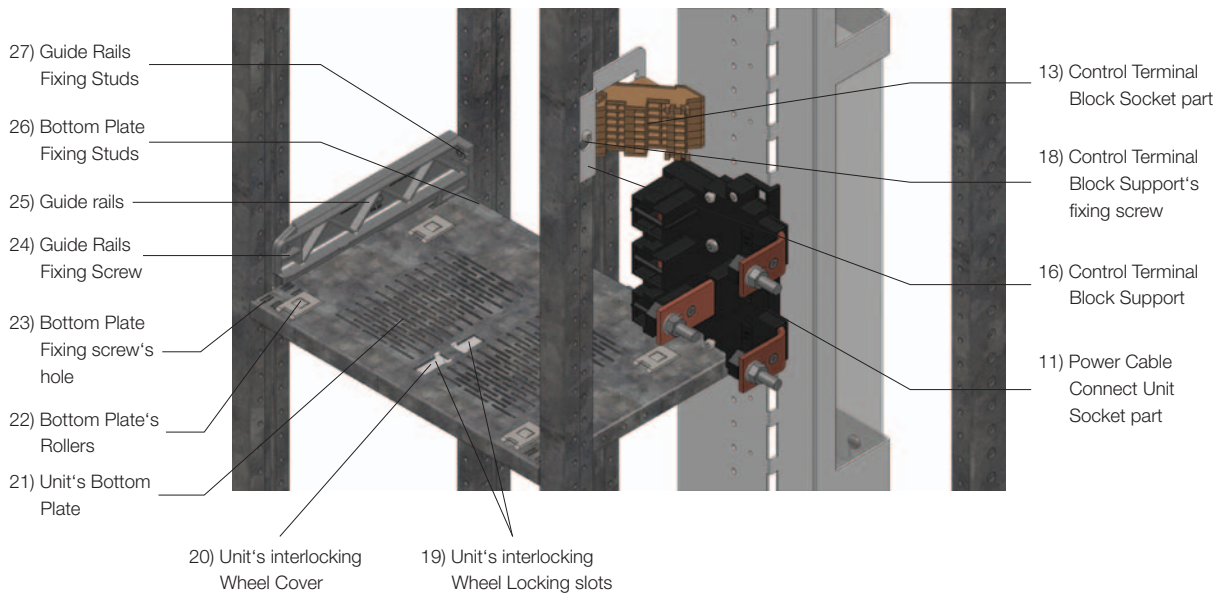

FIGURE 31. Unit Bottom Plate

Installing

Each unit fits in its cubicle within the vertical section. You may need to adjust the height of a cubicle when changing or adding units. Refer to the following two examples as a reference when adjusting the height of a cubicle.

To convert three 12E height (300 mm / 11.8 in) compartments to a single 36E height compartment follow this procedure:

Disassembly

- Pull out the three withdrawable units. (See Remove/Insert Withdrawable Units section)
- Disconnect power and control cables. Take out the two upper control terminal block supports (fig 33) with their control terminal blocks (fig 32).



FIGURE 32. Uninstall the Control Terminal Block



FIGURE 33. Uninstall the Control Terminal Block Support



FIGURE 34. Uninstall Power Cable Connection

The lower support may remain unchanged or, if necessary, can be relocated and converted to one or two, 12-pole control terminal blocks. When converting from two to one control terminal blocks, the remaining one must be at the top of the support.

Dismantle the two middle compartment bottom plates (fig 36) with their guide rails (fig 35). The lower bottom plate remains unchanged.

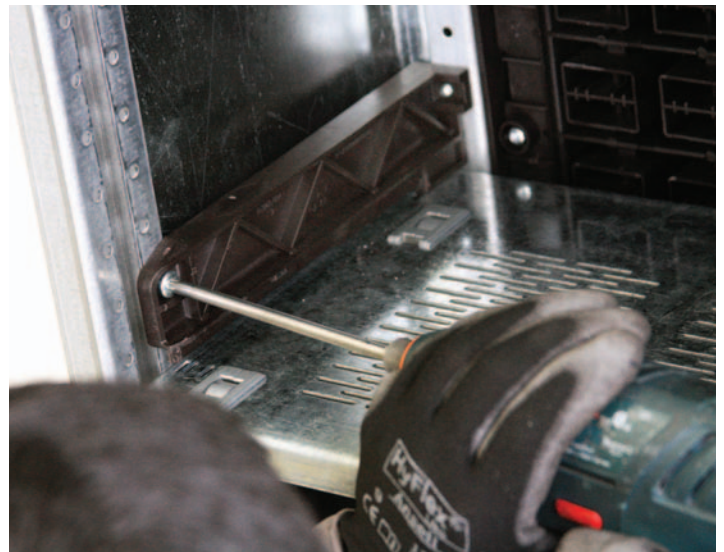

FIGURE 35. Dismantle Guide Rails



FIGURE 36. Dismantle Compartment Bottom Plates

- Depending upon module design; one or two power cable connection units may be removed (fig 34). When necessary; exchange the power cable connection unit (CCU40 or CCU300). Depending upon current or application, two power cable connection units have to remain or must be exchanged.

Reassembly

- Connect control wiring and power cables and install its protective cover (item 10).
- Insert new withdrawable unit size 36E. Should new material be required, contact the nearest ABB sales office or representative.

To convert one 36E height (900 mm / 35.4 in) compartments to three 12E height compartment follow this procedure:

Disassembly

- Pull out the existing withdrawable unit.
- If required exchange power cables or leave to be used by one of the units size 12E.
- Disconnect control wiring or leave to be used by one of the three units size 12E.
- The compartment bottom plate with the guide rail and the top compartment bottom plate will remain unchanged.



FIGURE 37. Withdrawable Units

Reassembly

- Insert two new compartment bottom plates (item 21) with a distance of 12E each and attached them using their studs and screws (items 26 & 24).
- The newly installed bottom plates must be equipped with the left guide rail, and the rollers and covers have to be mounted (items 22 & 20 of fig. 31).
- Mount one control terminal block support (item 16) with one or two 12-pole terminal blocks above each of the newly installed compartment bottom plates on the right-hand side (in the cable compartment) (item 13). If only one, 12-pole terminal block per support is required, it must be mounted in the upper part of the cut-out of the support.
- Install new power cable connection unit (CCU40 or CCU300) (item 11).
- Connect power cables and control wiring.
- Insert three, new withdrawable units size 12E. Should new material be required, contact the nearest ABB sales office or representative.

Installing

3.7. Fastening Sections to a Floor, Base Frame and Wall

A							
Distance between anchoring holes	350 mm (14 In)	400 mm (16 In)	500 mm (20 In)	600 mm (24 In)	700 mm (28 In)	800 mm (32 In)	1000 mm (40 In)
B							
Width Section	500 mm (20 In)	600 mm (24 In)	700 mm (28 In)	800 mm (32 In)	900 mm (36 In)	1000 mm (40 In)	1200 mm (48 In)

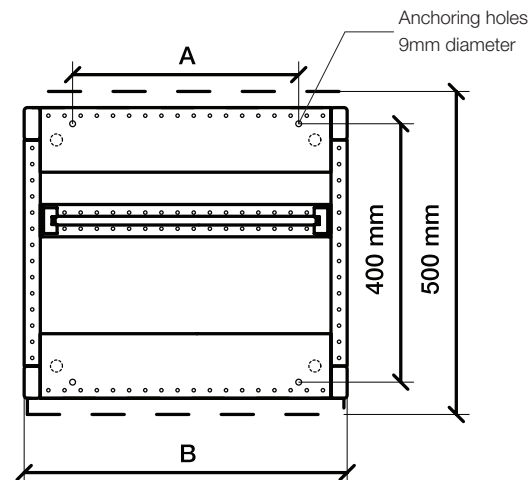

FIGURE 38. Mounting Dimension (table)

The Sections should preferably be erected on a base frame which is:

- Embedded in the concrete floor or
- Resting as a false floor on supports

Attach the MCC sections using two or four (as per supplied drawings) bolts through the holes in the section base to the floor or base frame. Use M8 (5/16 in) or larger hardware.

The MCC can be welded to the floor. However, it is recommended that the customer follow appropriate welding techniques and treat the welded area with a corrosion-resistant coating.

If mounted on a base frame or raised foundation, ensure that the height from the floor to the center of the top handles will comply with NFPA 70 National Electrical Code (NEC) Article 404.8 and UL Standard 845. The distance from the floor to the center of the highest handle must not be greater than 2043 mm (80 in) to comply with most standards.

3.8. Installation on False Floors

Ensure that the base of each section rests evenly on the supports. A minimum floor height of 500 mm or (20 in) is recommended to accommodate the bending radius of the cables and provide adequate accessibility.

- The horizontal tolerance of the frame must not exceed ± 1 mm (0.039 in) over a length of 1 m (39.4 in).
- The subfloor must be firm to avoid settling, especially when using insulation layers and adhesives.
- The false floor must have a carrying capacity of 20 kN/m² (2.9 PSI) compression load from top to bottom.

3.9. Cable Connections and Wiring

⚠ DANGER

Verify that all cables are de-energized prior to installing.

Installing Connections – General Information

All conduit installations should conform to local codes and be compatible with the NEMA environmental rating of the MCC. Install conduit away from the ground bus bar to avoid possible damage. Position the cable connection to minimize bending and maintain relative vertical alignment to incoming connections.

When installing cable, make sure the temperature is above 0 °C (32 °F) unless the cable is appropriate for installation at lower temperatures.

On every connection, verify the compatibility of wire size, type and stranding for the type of power terminations (lugs or terminals).

Use correct lugs in all applications. Crimp compression lugs with the manufacturer-recommended tools. Properly connect all line and load cables to avoid a bolted-fault and equipment damage.

Use the MCC electrical schematics provided to verify field wiring connection points.

Tighten any unused bolts.

If your installation has top incoming connections:

- Refer to the elevation drawings shipped with the MCC to check space availability for incoming cables.
- Make the connections only after the MCC is in place, leveled, anchored and the sections joined and spliced. Bring the conduit into the top of the incoming section.

If the top plate has to be modified for the incoming conduit, remove the lifting angle and top plate to perform the modifications. Do not drill or cut the top plate while still attached to the MCC in order to avoid metal chips falling into MCC, which can cause serious damage to the equipment.

After modification, replace the top plate and lifting angle bolts to guard against dust or dirt from entering the top horizontal wireway. The lifting angle bolts can also be removed and the holes plugged. See Crane Handling in this manual.

Optional bottom plates can be removed for modification.

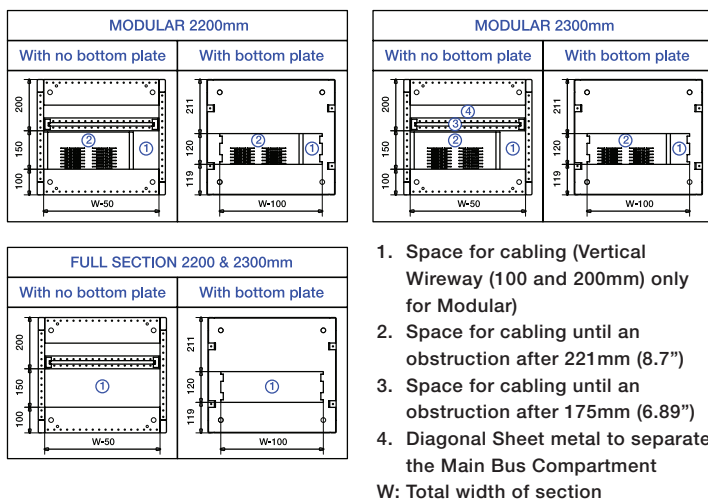

FIGURE 39. Floor Cut-outs

Locate conduit approximately 50 mm (2 in) above floor level.

CAUTION

Make sure all conduit stubs will clear the ground bus.

For approximate section base dimensions and ground bus locations, refer to the elevation and floor plan drawings shipped with the MCC.

Direct Connections to Main Sections, Fixed and Plug-In Units

For main sections, as well as fixed and plug-in units, entry space for connections is provided at the top or bottom of the MCC sections. The top plates (and bottom plates, if present) are removable to facilitate installing conduit or making other modifications. (See section above for more information)

For plug-in units, the hinged wireway door at top and bottom of the wireway allow direct access to the unit incoming or outgoing lugs.

If present, the horizontal wire railway must be removed to make connections.

The top and bottom horizontal wireway and the vertical wireway are dedicated to incoming lines, load and control wires. The horizontal wireway enables running control and power wires between sections.

The control cables run vertically in the vertical wireway at the right side of the vertical sections and are connected directly to the control terminal block.

Cable Connections to Withdrawable Units

WARNING

Failure to support cables can cause potentially hazardous mechanical deformation of terminals. Use the wire tie retainer holes provided in the enclosure to secure the cables.

Installing

Outgoing power connections and all control wire connections for withdrawable units are made in the vertical wireway, and can enter from either the top or bottom.

– Control Terminal Blocks (CTB):

- Each pole on the control terminal block has three terminals. Two of them are spade-type connectors and the third is a screw-type terminal.
- Wire range: 18 - 14 AWG stranded copper wire, rated 10 A/300 V. Ferrules are recommended for fine-strand wire.
- All control circuits must be connected to the withdrawable unit through this CTB.
- Torque: 0.8 Nm/7 lbs/in

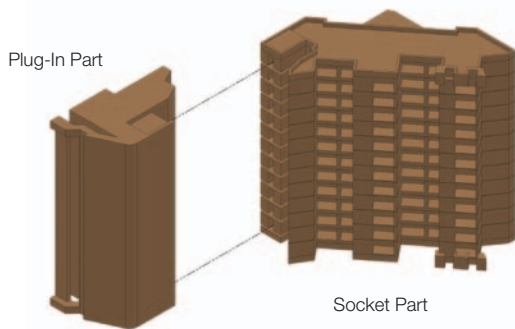

FIGURE 40. Control Terminal Block

– Power Cable Connection Unit (CCU 40):

- Rated 40 A/600 V.
- Wire range: 14 – 6 AWG, Cu only. 75° C.
- Torque: 6 Nm/52 lbs/in
- Strip length: 12 mm (1/2 in), (tool required: flat-blade screwdriver)

– Power Cable Connection Unit (CCU 300):

- Rated 300 A/600 V.
- Wire range: Accepts ring tongue terminals.
- Torque: 34 Nm/300 lbs/in

Wiring Between Shipping Splits

Run interconnecting wiring between sections in a shipping split through the horizontal wireway in the top and bottom of each section.

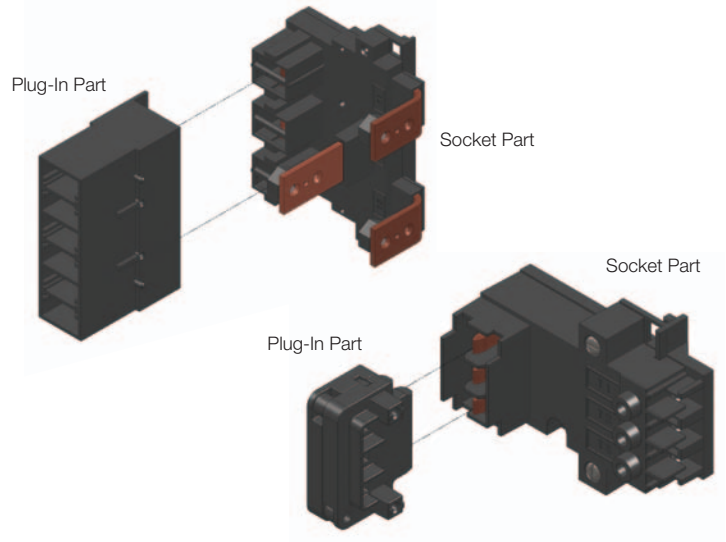

FIGURE 41. CCU40 & CCU300 Power Cable Connection Unit

To make connections between shipping splits, a pull-apart terminal block usually will be provided.

Connection to External Control Source (If required)

If an external control source is used, it should be stable and not subject to variations. Consult your ABB representative for minimum VA requirements.

Terminals will usually be provided in the top or bottom wireway of the first or last section of the line-up. More details will be found in the MCC drawings.

Neutral Conductor Connection (If provided)

Connect the neutral conductors to the neutral bar in the vertical wireway using compression lugs. Make the connection at the height of the relevant unit. See Figure 8.

3.10. Other Installation Information

Interruption of Installation

If work is interrupted during installation or connection, take appropriate measures to ensure that dust, moisture and foreign objects are not allowed to enter the MCC enclosures.

Close the section doors whenever installation work stops or is delayed. For interruptions lasting more than a day, cover the sections with plastic sheets or shrink wrap.

In damp or humid environments, use heaters to prevent condensation. See the Temporary Storage section of this manual for more information.

Storing Unit Outside the MCC

If you remove units from the MCC for any reason, you must protect them by covering or wrapping them in plastic and marking them with their location so they can be returned to the proper location in proper lineup.

If you relocate the location of a unit within the MCC, ensure that the unit is marked to indicate its new location. The drawings should also be updated.

Surface Damage

To extend the life and ensure the safe operation of your MCC, keep the exterior clean and in good condition.

To remove grease or oil on the exterior, use a solvent cleaning agent (e.g. 3M™ Prep Solvent-70 Cleaner) and a cloth or disposable wipe.

Repair scratches to the paintwork with ABB supplied touch-up paint. If touch-up paint was not supplied, contact your ABB representative. See the Exterior Metal Damage Repair section in this manual for repair instructions.

Adding/Upgrading a Unit

Do not exceed the maximum amperage available for the vertical section

Install the correct power cable connection unit and control terminal block

Adjust the compartment bottom plate to the appropriate height. Adjust the bucket height as described in the Changing Compartment Height section. Update the drawings.

You can move the control terminal block support and power cable connection unit as required for the unit terminals.

NOTICE

Always consult ABB before adding new units or increasing total load within vertical sections. Changes to total electrical load within a vertical section can result in increased heat, possibly leading to equipment damage and reduced life.

Adding new units or increasing the total load may void your warranty.

3.11. Commissioning

Physical Equipment Check

Check all of the following items related to the installation and site before energizing the MCC:

- Are the MCC shipping splits connected properly and the lineup firmly attached to the foundation or false floor?
- Are shipping-split bus splices at all bars tightened to the proper torque? Refer to the Torque Table in this manual.
- Are all of the factory-installed splice connections still at the proper torque as indicated by the alignment of the painted marks on the bolts?
- Are all barriers, plates, doors and locks in place?
- Are the bottom plates, if used, properly installed.
- Are all tools, dirt/debris, shipping/packing materials and other foreign objects removed from inside the MCC?
- Is the equipment properly grounded?
- Is the phase sequence marking correct?
- Have all withdrawable units been inserted and removed to test interlock?

Installing

Prepare to Energize the MCC

⚠ DANGER

Always use properly insulated tools and instruments during commissioning. Short circuit current in low-voltage MCCs are typically very high. Depending on trip settings, high short circuits with long durations can occur.

Follow all codes and regulations related to servicing and installing electrical equipment. Failure to follow these instructions can result in short circuit and electrical arcing.

Check all of the following items related to the electrical connections and systems before energizing the MCC.

- ✓ Ensure the electrical characteristics of the MCC (e.g. rated voltage, short circuit current rating, grounding system, etc.) are compatible with the site conditions.
- ✓ Inspect the withdrawable units, following the instructions in the Inspecting Units section of this manual.
- ✓ Inspect the unit contacts, following the instructions in the Inspecting Units section of this manual.
- ✓ Using the proper tool for each connection, verify the tightness of all control and power terminals within the units.
- ✓ Insert all necessary fuses in the main and auxiliary circuits, verifying that they match the apparatus list and the circuit diagram.
- ✓ Set the main circuit protective device feeding the MCC to its lowest value.
- ✓ Set the units' protective devices to the specified values.
- ✓ If present, verify that current transformers are properly connected or short-circuited.
- ✓ If an external control voltage is present, verify that it is OFF.
- ✓ Close and latch all doors.
- ✓ Test electrical insulation resistance using a megger with a potential of 500-1000 V. Conduct the test phase-to-phase, phase-to-ground, and when applicable, phase-to-neutral. Conduct the test with all unit disconnects in the OFF position. If the MCC is equipped with potential transformers (for metering, etc.) remove the primary fuses prior to performing the test. Typical insulation resistance values should be $\geq 100 \text{ M}\Omega$.

NOTE: When conducting an electrical insulation resistance test, isolate equipment sensitive to high test voltages, such as meters, solid state devices, motor winding heaters and capacitor units. Following successful completion of the test, reconnect all relays, operating voltages, circuits and fuses.

Energize the MCC

⚠ DANGER

Use appropriate personal protective equipment (PPE) and follow safe electrical rules and work practices for electrical installations as described in standard NFPA 70E, and any other local safety rules and practices.

After completing all of the previous steps related to installation and commissioning, energize the MCC following these steps:

- Apply power on the main incoming.
- Verify that the incoming phase sequence is correct.
- Switch on the main disconnect.
- Check the phase sequence of each unit
- If existing, switch on any external power sources.

Final Testing

Check that all instrumentation is working properly and the readings are within specifications or reasonable levels.

Check that all instantaneous protections that were turned down during previous testing are reset to their operating positions.

4. Operation

Circuit breakers, fusible disconnects, contactors, relays and other components may have documentation that describes operating instructions that are not included in this manual. Review any documentation provided with those components prior to operating the MCC.

4.1. Fixed and Plug-in Units

No special operating instructions are required for fixed or plug-in units. However, the internal components may have separate instructions. If these individual manuals are not supplied, contact your ABB representative.

4.2. Withdrawable Units

These types of units allow you to remove or insert it in its cubicle without interrupting power to the MCC main bus. This is possible through the combined action of the operating handle position and unit physical position.

Rotary Operating Handle

This handle has five positions: ON, TRIP, OFF, TEST and MOVE.

Unit Physical Positions

Withdrawable units have four (4) physical positions:

ENGAGED – Unit is full inserted and connected to power.

ISOLATED – Unit is moved approximately 30 mm (1.2 in) out to the first detent, disconnected from power.

WITHDRAWN – Unit is moved almost entirely out of the MCC, stopped by a mechanical latch on the left rail of the unit.

REMOVED – Unit is fully extracted from the MCC.

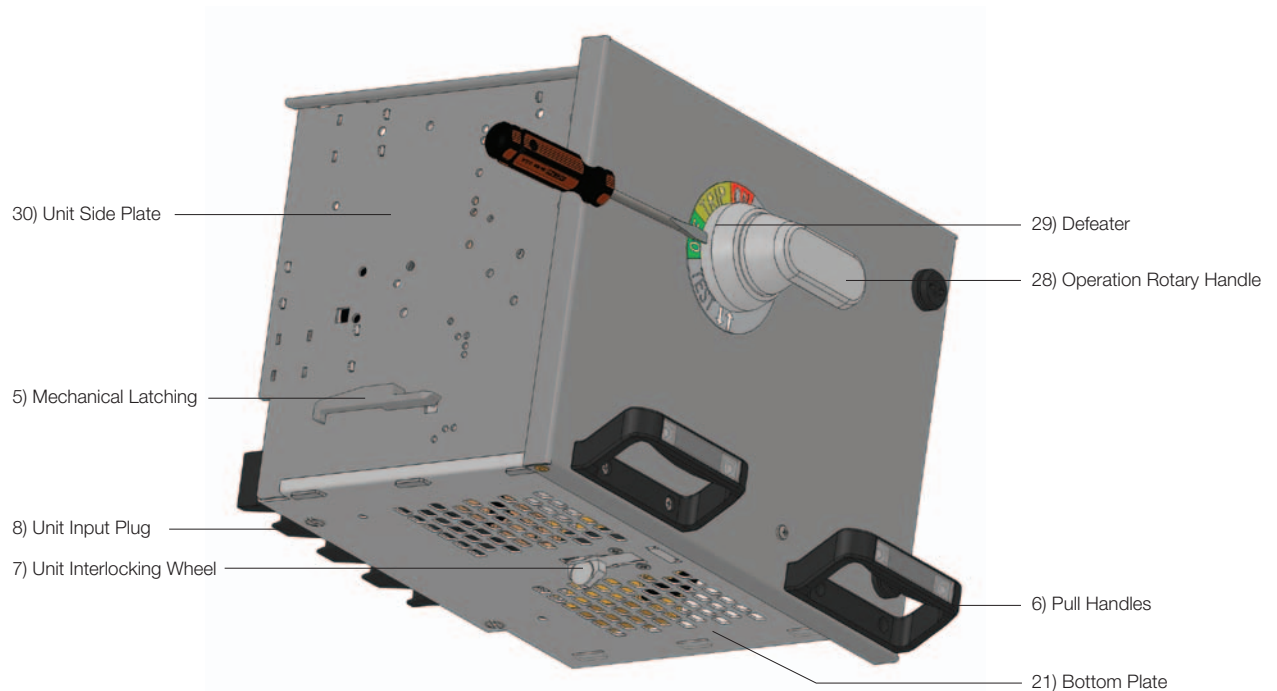

FIGURE 42. Withdrawable Unit

Operation

Units status

The table below shows the Unit Status based on the rotary handle position and physical location of the unit.

	Operating Handle Position	Unit Physical Position	Unit Status	Comments
	ON	Engaged	On	Unit's main disconnect and control circuits are closed.
	OFF (Lockable with up to 3 padlocks)	Engaged	Off	Unit's main disconnect and internal control circuits are off. External control power will remain connected.
		Isolated	Off	Unit in this status will have both the power and the control circuits physically disengaged from their sockets. The drawer will be 30mm drawn out of the cubicle and is locked (Cannot be inserted nor removed).
		Withdrawn	Withdrawn	Unit can be removed outside the MCC (A safety mechanical latch must be defeated).
	TRIP	Engaged	Tripped	Unit's main breaker tripped after a fault. The trip can be reset by moving the handle to the OFF position.
	TEST* (Lockable with up to 3 padlocks)	Engaged	Test	Unit's main disconnect is OFF. Unit's control circuitry is energized via an auxiliary control power. The user can conduct a functionality check test.
	MOVE	Engaged	Ready to change Position	Unit's main disconnect is OFF. Drawer holding mechanism is unlocked. The unit is ready to be moved to the Isolated status.
		Isolated	Ready to change Position	Drawer holding mechanism is unlocked. The unit is ready to be moved to the Withdrawn position or return to the Engaged position.

*Only, where provided

The rotary operating handle can be locked in the OFF position while the unit is in any of the following physical positions; ENGAGED, ISOLATED or WITHDRAWN.

It can also be locked while in the TEST position.

The withdrawable units include a safety interlock mechanism that allows insertion or withdrawal of the unit only when the handle is in the MOVE position. In this handle position, the disconnecting means will be OFF.

Referred to the Remove/Insert Withdrawal Units section of this manual for instructions on removing the unit.

Test Position (If provided)

You can put the unit in the TEST mode without physically moving the withdrawable unit by turning the operating handle to the TEST position.

For safety, you can lock the operating handle in the OFF positions using up to three padlocks.

When withdrawable units are not being used, move the operating handle to the OFF position.

Opening the Door

The rotary operating handle mechanism prevents opening the door unless it is in the OFF position. You can defeat the door interlock when in the ON position using a tool. (Item 29 of fig. 42).

⚠ DANGER

Opening the front covers while the operating handle is in the ON position exposes you to hazardous voltage levels.

Only trained individuals wearing correct personal protective equipment should attempt to open unit door while energized.

5. Maintenance

A well-planned and executed maintenance program will ensure uptime, extend equipment life and reduce overall costs. Routine maintenance is less costly than the emergency repairs and parts typically required to correct unexpected equipment failures.

For information on the mechanical and electrical life of components included in the MCC, refer to the individual product documentation.

ABB offers a range of preventive maintenance services and programs. ABB can also provide ABB-trained expert technicians and give you fast access to OEM parts. Contact your ABB representative for more information.

5.1. General Safety Instructions

DANGER

Maintenance work on this equipment should only be performed by qualified personnel wearing proper personal protective equipment.

- Always use an appropriate voltage-sensing device to confirm that the power is off prior to installing or working with the MCC.
- National and international standards for the installation, operation and maintenance of electrical equipment specify that your facility must be in clean and orderly condition.
- When performing any work on the MCC, maintenance staff must comply with the relevant safety regulations and standards. That includes both national and international safety rules (e.g. NFPA 70E, regulations for the operation of power installations) and any specific maintenance instructions for the installed devices.

5.2. Lock out/Tag out

The MCC provides the ability to padlock the operating handle of a unit in the OFF position to prevent changing the status or position of a unit. Up to three padlocks can be used.

Follow your local authority having jurisdiction and/or facility's procedures for properly locking out / tagging out equipment during maintenance.

5.3. Tighten Unit Control and Power Terminals

Recommended Interval: Perform annually or based on your local maintenance schedule.

Using the proper tool for each connection, verify the tightness of all control and power terminals within the units.

While tightening the terminals, be alert for any signs of heat damage, which indicates potential problems or loose connection. Heat generated by inadequate terminal torque is one of the leading causes of equipment malfunction and failure. When heat damage is observed, it typically indicates damage to the component requiring repair or replacement.

5.4. Remove/Insert Withdrawable Units

You may need to withdraw or remove a unit for repair, update or testing. The MCC allows units to be easily replaced without de-energizing the entire MCC. Even with a unit removed, the IP20-compliant design of the multi-function wall prevents unintended contact with energized areas. However, it is still possible to intentionally insert your fingers or accidentally make contact with energized areas with tools.

Therefore, you may continue to operate the MCC with a unit removed. If the unit will be removed for an extended period of time, it's advisable to replace it with another unit or to temporarily enclose the hole where the unit was removed with a door.

Move a Unit to the Isolated Position



FIGURE 43. Isolated Position

1) Rotate the operating handle to the MOVE position. The disconnecting means within the unit is now in the OFF position.

2) Grasp the pulling handles and firmly withdraw the unit. The unit will move approximately 30 mm (1.2 in) and stop. The operating handle returns automatically to the OFF position. If the handle does not return to the OFF position, see Troubleshoot Withdrawable Unit Interlock. The unit is now in the ISOLATED position; all power and control electrical contacts are disengaged.

3) The unit can be padlocked in this position, preventing it from being moved.

Removing a Unit

1) To remove a unit, rotate the operating handle to the MOVE position.

NOTE: The circuit protective device within the unit must be turned OFF since the operating handle must be moved through the OFF position in order to reach the MOVE position, preventing a unit from being removed under load.

Pull firmly and sharply on the two pull handles on the door. The unit should move out of the MCC cubicle approx. 30 mm (1.2 in) and stop in the ISOLATED position. The operating handle will spring return to the OFF position. The unit is now locked in place and cannot move either inward or outward with the operating handle in the OFF position.

In this ISOLATED position, all power and control contacts connected via the control or power terminals are disengaged and the unit is electrically isolated. See (fig. 43).

2) Rotate the operating handle again to the MOVE position and pull the unit outward sharply again. The unit will move out of the cubicle approx. 50 mm (1.97 in) to the WITHDRAWN position and stop. The unit is retained in the cubicle by the thumb operated safety stop (mechanical latch) on the lower left side of the unit



FIGURE 44. Mechanical Latch Mechanism

WARNING

Do not leave the unit in the WITHDRAWN position longer than necessary since it is beyond its center of gravity and prone to mechanical damage

NOTICE

Use of partially withdrawn units or pulling handles as climbing aids will damage the units and may break the plastic pull handles

Maintenance

3) To completely remove the unit from the MCC cubicle, grasp the unit firmly and be ready to accept its weight. Press down on the thumb-operated safety stop to release it, and slide the unit the remainder of the way out of the cubicle. Units, especially the 18E and larger may require two people to handle the weight safely, spring loaded handles may be provided on the left and right side of the unit for handling purposes.

TIP: If the unit is outside the section and placed on a flat surface, the weight of the unit will depress the interlock wheel on the bottom of the unit (Item 7 of Fig. 30). This may prevent the unit's door from opening or closing properly and may prevent the unit from locking into position when reinserted in the cubicle.

To avoid this problem, and to open the door while the unit is outside its cubicle, tilt the unit backward slightly to allow the wheel, which is spring loaded, to fully extend.

Insert a Unit

The handle must be in the OFF position.

NOTICE

Do not use the pull handles to lift or carry the unit.

- 1) Insert the unit into the section, ensuring that it is level with the floor. Push the unit in until it stops, at which point it will engage the mechanical stop on the left-hand side of the unit, preventing it from falling out of the MCC cubicle.
- 2) Rotate the operating handle to the MOVE position and push the unit until it reaches the ISOLATED position, where it will stop. The handle spring returns to the OFF position. The unit is now locked in place. All power and control electrical contacts remain disengaged in this position and no part of the unit is energized or connected to any external wiring, power or control, line or load.

If the handle does not return to the OFF position, see the Troubleshoot Withdrawable Unit Interlock section of this manual.

- 3) Rotate the operating handle again to the MOVE position and push firmly and sharply until the unit reaches the ENGAGED position. You need to generate some momentum when pushing to overcome the friction as the power plugs engage. The handle returns to the OFF position. The unit is now fully ENGAGED and ready to energized

TIP: If the unit does not fully move into the ENGAGED position, you may have to withdraw the unit again to the ISOLATED position and repeat step 3. Advance the unit sharply and firmly when moving it into the ENGAGED position.

Ensure that the unit is fully engaged by pulling sharply on the two pull handles. The unit should be locked in place. If it moves, return the handle to the MOVE position and withdraw the unit to the ISOLATED position. Then follow the above procedure to reinsert the unit to the ENGAGED position. Test to ensure that it is locked in place.

- 4) You can now energize the unit by rotating the handle to the ON position.

5.5. Troubleshoot Withdrawable Unit Interlock

If the handle fails to spring back automatically to the OFF position as the unit is moved from WITHDRAWN to ISOLATED to ENGAGED, (or in the reverse order when being removed from the MCC section) the connection between the locking wheel on the bottom of the unit and the operating handle mechanism is improperly adjusted.

To correct this problem, adjust the flat metal shaft (Item 4 of Fig. 30) vertically oriented on the rear of the withdrawable unit door, extending between the operating mechanism and the bottom of the door.

Loosening the screw at the base of the operating mechanism that holds the shaft in place. The slotted hole in the shaft allows it to be adjusted up and down slightly after loosening the screw.

When the unit door is closed, another slotted hole in the bottom of the shaft engages a Spring-loaded lever (Item 17 of Fig. 30) at the bottom center of the unit. This lever is connected to the interlock wheel on the bottom of the unit. This wheel is lifted when the operating handle is rotated to the MOVE position, allowing the unit to be moved in or out of the MCC cubicle.

As the unit moves, the wheel will drop into one of two recesses in the steel shelf that supports the unit in the MCC section, locking the unit in place. These two recesses in the bottom plate accept the wheel in the ENGAGED and the ISOLATED unit positions, locking the unit in place and preventing it from moving unless the operating handle is again placed in the MOVE position.

Adjust the shaft as necessary so that it engages the spring-loaded wheel lever on the unit chassis, allowing smooth closure of the door and providing for correct and reliable operation of the unit interlock mechanism. When properly adjusted, the operating handle will reliably spring back to the OFF position after being moved to the ENGAGED and ISOLATED positions.

5.6. Inspect Units

Recommended Interval: Perform prior to first installation and periodically according to your local maintenance schedule.

- Visually inspect the contacts for damage. Look for excessive wear or damage (e.g. worn silver or tin layer, signs of excessive heat, etc.) on all contact surfaces, including distribution bars, withdrawable units, power cable connection unit, etc. If you are unsure of the contact condition, measure the contact clearance with a slide or standard gauge. The clearance must be 4.7 mm +0.05/-0.2 (0.18 in +.002/-0.001).
- Test for contact float. The power contacts are contained in a black plastic housing for incoming and outgoing power connections. These contacts must move freely from side to side, indicating that they are properly installed. Verify that contacts are movable and properly snapped into position in the withdrawable unit rear wall or contact apparatus housing.
- Using the proper tool for each connection, verify the tightness of all control and power terminals within the units.
- Be sure that the contacts are properly greased. If they appear dry, use a brush to apply the appropriate amount of contact grease, e.g. Fuchs CHEMPLEX® 825. Each unit will require approximately 3.5g of lubricant to grease both the incoming and outgoing contacts.

If you detect contact damage, we recommend replacing the entire withdrawable unit chassis or the entire contact system. Contact your ABB representative for assistance with repair or replacement.

5.7. Exterior Metal Damage Repair

Any scratches or damage to the surface of the vertical sections must be repaired in order to avoid oxidation, which can reduce the life of the equipment.

For small areas of damage, ABB supplied touch-up paint kits are available. To obtain a kit, contact your ABB representative.

5.8. Maintenance Schedule

WARNING

Defects or deficiencies in any electrical equipment should be remedied immediately. If immediate repair is not possible, Lockout/Tagout the equipment until after repairs have been made, or replace the withdrawable unit.

It is highly recommended that you establish a periodic maintenance program for the MCC. The frequency of maintenance activities depends on equipment usage and the operating environment.

5.9. Arc Flash Protection

The National Fire Protection Association (NFPA 70E) has established the flash protection marking requirement¹ that applies to personnel who install, maintain, or repair electrical systems.

Article 110.16-Flash Protection of the NEC (Version 2002) stated:

Switchboards, panelboards, industrial control panels, and MCCs that are in other than dwelling occupancies and are likely to require examination, adjustment, servicing, or maintenance while energized shall be field marked to warn qualified persons of potential electric arc flash hazards. The marking shall be located so as to be clearly visible to qualified persons before examination, adjustment, servicing, or maintenance of the equipment.

FPN No. 1: NFPA 70E-2000, Electrical Safety Requirements for Employee Workplaces, provides assistance in determining severity of potential exposure, planning safe work practices, and selecting personal protective equipment.

FPN No. 2: ANSI Z535.4-1998, Product Safety Signs and Labels, provides guidelines for the design of safety signs and labels for application to products.

The flash criteria are regularly updated as the technology changes. The latest editions of the NEC and NFPA 70E should be used in establishing potential electric arc flash hazards and arc flash marking.

The required flash protection marking is to be applied by the MCC end user for each installation. It is similar to other NEC marking requirements such as voltage, voltage hazard labels, and circuits.

1. Standard for Electrical Safety Requirements for Employee Workplaces. NFPA 70E

Maintenance

Flash protection markings, however, must be based on application information and calculations from the installation site. This information helps to identify the presence of a potential flash hazard and provide guidance in determining necessary personal protective equipment to be worn by installation and maintenance personnel.

You must establish field marking requirements based upon:

- Level of onsite personnel safety training.
- Level of required clothing and required PPE.
- Consistency for the level of marking for various equipment, for example: switchgears, switchboards, MCCs and other panels.
- Available flash energy on each piece of equipment as determined by available fault current and arc flash duration possible based on the type and degree of short circuit protection equipment.

5.10. Additional Resources

In addition to this manual, the following documents may provide information that will be useful as you install, operate and maintain the MCC.

- 1SDH000532R0002 (New Emax user manual)
- RH0012002 (Tmax T2 installation manual)
- 1SDH000436R0002 (Tmax T4 installation manual)
- 1SDH000437R0002 (Tmax T5 installation manual)
- 1SDH000511R0004 (Tmax T6 installation manual)
- 1SDH000606R0003 (Tmax T7 installation manual)
- 1SFC132003M0201 (Soft starter installation manual)
- 2CDC135013D0202 (UMC100 technical description)

6. Torque Tables

⚠ WARNING

Heat generated by improper terminal torque is one of the leading causes of equipment failure.

6.1. Product Assembly Torque Application

Introduction:

The following torque tables apply to horizontal and vertical bus bar screw connections, electrical component screw connections, terminal connections and structural components of the MCC.

NOTE: For equipment connections and mountings, see the manufacturer's technical data sheets.

Tightening Torque Tables

Main Bus Splice Links Recommended Torque		
Component Description	Size	Recommended Torque Nm
Main Horizontal Bus Splice Links	M8	35
Horizontal Ground Splice Links	M8	35
Neutral Horizontal Bus Splice Links	M8	35

Withdrawable Unit's Terminal block		
Component Description	Screw Type	Recommended Torque Nm
Control Terminal Block	Screw-type	0.8
Power Cable Connection Unit (CCU 40)	Screw-type	6
Power Cable Connection Unit (CCU 300)	Accepts ring tongue terminals	35

Torque Tables

Torque table for components fixed in sheet metal 1.5mm S				
Component Description	Type	Size	Torque Nm (Nominal)	Torque Nm (Max)
MCCB	T2	M4	1.7	2
	T4	M5	3.2	3.8
	T5	M5	3.2	3.8
	T6	M5	3.2	3.8
	T7	M5	3.2	3.8
Fusible Switch	OS30	M4	1.7	2
	OS60	M5	3.2	3.8
	OS100	M5	3.2	3.8
	OS200	M5	3.2	3.8
	OS400	M5	3.2	3.8
	OS600	M8	5.5	6.5
	OS800	M8	5.5	6.5
Contactor	A9	M4	1.7	2
	A16	M4	1.7	2
	A26	M4	1.7	2
	A50	M6	3.2	3.8
	A75	M6	3.2	3.8
	A145	M5	3.2	3.8
	A260	M5	3.2	3.8
	AF460	M5	3.2	3.8
	AF750	M6	3.2	3.8
Overload Relays	E16	M4	1.7	2
	E45	M4	1.7	2
	E80	M5	3.2	3.8
	E140	M5	3.2	3.8
	E200	M5	3.2	3.8
	E320	M5	3.2	3.8
	E500	M5	3.2	3.8
	E800	M6	3.2	3.8
	TA25	M4	1.7	2
	TA42	M4	1.7	2
	TA75	M4	1.7	2
	TA110	M5	3.2	3.8
	TA200	M5	3.2	3.8
TA450	M5	3.2	3.8	
VFD ACS 350	R0	M5	3.2	3.8
	R2	M5	3.2	3.8
	R3	M5	3.2	3.8
	R4	M5	3.2	3.8
VFD ACS 550	R1	M5	3.2	3.8
	R2	M5	3.2	3.8
	R3	M6	3.2	3.8
	R4	M6	3.2	3.8
	R5	M6	3.2	3.8
	R6	M8	5.5	6.5
VFD ACS 800	R2	M5	3.2	3.8
	R3	M6	3.2	3.8
	R4	M6	3.2	3.8
	R5	M6	3.2	3.8
	R6	M8	5.5	6.5
Softstarters	PST72	M6	3.2	3.8
	PST142	M6	3.2	3.8
	PST300	M6	3.2	3.8
	PST370	M6	3.2	3.8
	PST1050	M6	3.2	3.8

Torque table for components fixed in sheet metal 2 mm				
Component Description	Type	Size	Torque Nm (Nominal)	Torque Nm (Max)
MCCB	T2	M4	1.7	2
	T4	M5	3.2	3.8
	T5	M5	3.2	3.8
	T6	M5	3.2	3.8
	T7	M5	3.2	3.8
Fusible Switch	OS30	M4	1.7	2
	OS60	M5	3.2	3.8
	OS100	M5	3.2	3.8
	OS200	M5	3.2	3.8
	OS400	M5	3.2	3.8
	OS600	M8	5.5	6.5
	OS800	M8	5.5	6.5
Contactor	A9	M4	1.7	2
	A16	M4	1.7	2
	A26	M4	1.7	2
	A50	M6	4.6	5
	A75	M6	4.6	5
	A145	M5	3.2	3.8
	A260	M5	3.2	3.8
	AF460	M5	3.2	3.8
	AF750	M6	4.6	5
Overload Relays	E16	M4	1.7	2
	E45	M4	1.7	2
	E80	M5	3.2	3.8
	E140	M5	3.2	3.8
	E200	M5	3.2	3.8
	E320	M5	3.2	3.8
	E500	M5	3.2	3.8
	E800	M6	3.2	3.8
	TA25	M4	1.7	2
	TA42	M4	1.7	2
	TA75	M4	1.7	2
	TA110	M5	3.2	3.8
	TA200	M5	3.2	3.8
TA450	M5	3.2	3.8	
VFD ACS 350	R0	M5	3.2	3.8
	R2	M5	3.2	3.8
	R3	M5	3.2	3.8
	R4	M5	3.2	3.8
VFD ACS 550	R1	M5	3.2	3.8
	R2	M5	3.2	3.8
	R3	M6	4.6	5
	R4	M6	4.6	5
	R5	M6	4.6	5
	R6	M8	5.5	6.5
VFD ACS 800	R2	M5	3.2	3.8
	R3	M6	4.6	5
	R4	M6	4.6	5
	R5	M6	4.6	5
	R6	M8	5.5	6.5
Softstarters	PST72	M6	4.6	5
	PST142	M6	4.6	5
	PST300	M6	4.6	5
	PST370	M6	4.6	5
	PST1050	M6	4.6	5

Control And Auxiliary Contacts				
Component Description	Type	Size	Torque Nm (Nominal)	Torque Nm (Max)
Auxiliary Contacts	(*)	M 3.5 - Pozidrive	0.85	1

*Applies for all control auxiliary contacts (MCCB, FS, contactors, overloads, Pilot devices, etc.)

Power Terminals				
Component Description	Type	Size	Torque Nm (Nominal)	Torque Nm (Max)
MCCB	T2	M6	5.1	6.0
	T4	M8	15.3	18.0
	T5	M10	23.8	28.0
	T6	(2) M6	7.7	9.0
	T7	(2) M10	15.3	18.0
Fusible Switch	OS30	Terminal screw	1.7	2
	OS60	Terminal screw	3.0	3.5
	OS100	M5	4.8	5.6
	OS200	M5	15.3	18.0
	OS400	M5	36.0	42.4
	OS600	M8	48.0	56.5
	OS800	M8	48.0	56.5
Contactor	A9	Terminal screw	0.9	1.0
	A16	Terminal screw	0.9	1.0
	A26	Terminal screw	1.4	1.7
	A50	Terminal screw	3.4	4
	A75	Terminal screw	3.4	4
	A145	M8	15.3	18.0
	A260	M10	23.8	28.0
	AF460	M10	36	42.4
	AF750	M6	6	1
AF750	M12	38.3	45	
Transformers	T Series	Terminal screw	1.5	1.8
Overload Relays	E16	Terminal screw	0.9	1
	E45	Terminal screw	2	2.3
	E80	Terminal screw	5.1	6
	E140	Terminal screw	5.1	6
	E200	M5	15.3	18
	E320	M5	36	42.4
	E500	Terminal screw	0.9	1
	E800	Terminal screw	0.9	1
	TA25	Terminal screw	1.2	1.4
	TA42	Terminal screw	3.4	4
	TA75	Terminal screw	3.4	4
	TA110	Terminal screw	8.2	9.6
	TA200	M5	15.3	18
	TA450	Terminal screw	1.2	1.4

Power Terminals				
Component Description	Type	Size	Torque Nm (Nominal)	Torque Nm (Max)
VFD ACS 350	R0	Terminal screw	0.7	0.8
	R2	Terminal screw	0.7	0.8
	R3	Terminal screw	1.4	1.7
	R4	Terminal screw	2.1	2.5
VFD ACS 550	R1	Terminal screw	1.2	1.4
	R2	Terminal screw	1.2	1.4
	R3	Terminal screw	1.5	1.8
	R4	Terminal screw	1.7	2
	R5	Terminal screw	12.8	15
	R6	Terminal screw	34	40
VFD ACS 800	R2	Terminal screw	1.3	1.5
	R3	Terminal screw	1.3	1.5
	R4	Terminal screw	3.4	4
	R5	Terminal screw	12.8	15
	R6	Terminal screw	34	40
	Softstarters	PST72	M8	5.1
PST142		M8	7.7	9
PST300		M8	15.3	18
PST370		M10	34	40
PST1050		M12	38.3	45

Main Bus Bar Connection Sets				
Component Description	Type	Size	Torque Nm (Nominal)	Torque Nm (Max)
MCCB Connection set	T2, T4, T5	M10	50	55

Torque Tables

Mechanical connections thread rolling screws in metal				
Sheet metal				
Component Description	Size	Material Thickness (mm)	Torque Nm (Nominal)	Torque Nm (Max)
TORX pan head	M3	1.5	0.9	1
	M4	1.5	1.7	2
TORX counter sunk	M5	1.5	3.8	5
	M6	2	4.7	6
Hex head screw grade 8.8	M8	3	8.1	10
Aluminum Sheet				
Pozidrive screw	M3	3	0.9	1
	M4	3	1.7	2
Hex socket head cap	M5	3	3.8	4.5
	M6	3	4.7	5.5
	M8	3	4.7	5.5
	M8	5	8.1	9.5

Mechanical connections thread rolling screws in PLASTICS			
Plastic			
Type	Size (mm)	Torque Nm (Nominal)	Torque Nm (Max)
Torx pan Head	M4	1.7	2
	M5	3.8	4.5
	M6	4.7	5.5
	M7	-	-
	M8	3	3.5
	M9	3	3.5
Type	Size (mm)	Torque Nm (Nominal)	Torque Nm (Max)
Hex Allen Socket	M6	6.8	8
	M8	17	20
	M10	34	40
Hex Head Screw	M12	60	70
	M16	119	140

Contact Us

USA

ABB Inc.
Low Voltage Products & Systems
3700 W Sam Houston Pkwy S
Houston, TX 77042
Toll Free: 1 888 385-1221

ABB Inc.
Low Voltage Products & Systems
400 Crown Colony Drive, Suite 303
Quincy, MA 02169

www.abb.us/lowvoltage

Canada

ABB Inc.
Low Voltage Products & Systems
2117 - 32e Avenue
Lachine, QC H8T 3J1
Tel.: 1 514 420-3100
Toll Free: 1 800 567-0283
Fax: 1 514 420-3137
lvs.rfq@ca.abb.com

ABB Inc.
Low Voltage Products & Systems
201 Westcreek Blvd.
Brampton, ON L6T 5S6
Tel.: 1 905 460-3000
Fax: 1 905 460-3395

ABB Inc.
Low Voltage Products & Systems
110, 4411-6th Avenue S.E.
Calgary, AB T2G 4E8
Tel.: 1 403 278-7111
Fax: 1 403 278-8232

www.abb.ca/lowvoltage

Mexico

ABB Mexico, S.A. de CV.
Low Voltage Systems
Av. Central No. 405, Parque Logístico
C.P. 78395, San Luis Potosí, SLP
Tel.: +52 444 8708 000

While all care has been taken to ensure that the information contained in this publication is correct, no responsibility can be accepted for any inaccuracy. The Company reserves the right to alter or modify the information contained herein at any time in the light of technical or other developments. Technical specifications are valid under normal operating conditions only. The Company does not accept any responsibility for any misuse of the product and cannot be held liable for indirect or consequential damages.

©Copyright 2012 ABB Inc. All rights reserved.

2TDA090000P0001/March 2012